

**U.S. Department of Energy (DOE)  
Office of Energy Efficiency and Renewable Energy (EERE) and  
Office of Electricity (OE)**

**Innovative DEsigs for high-performAnce Low-cost HVDC  
Converters (IDEAL HVDC)**

**Funding Opportunity Announcement (FOA) Number: DE-FOA-0003141**

**FOA Type: Initial**

**Assistance Listing Number: 81.087**

<b>FOA Issue Date:</b>	9/27/2023 - 5:00 p.m. ET
<b>Submission Deadline for Concept Papers:</b>	11/14/2023 - 5:00 p.m. ET
<b>Submission Deadline for Full Applications:</b>	2/5/2024 - 5:00 p.m. ET
<b>Expected Submission Deadline for Replies to Reviewer Comments:</b>	3/19/2024 - 5:00 p.m. ET
<b>Expected Date for EERE Selection Notifications:</b>	June 2024
<b>Expected Timeframe for Award Negotiations:</b>	September 2024

- Applicants must submit a Concept Paper by 5:00 p.m. ET on the due date listed above to be eligible to submit a Full Application.
- To apply to this FOA, applicants must register with and submit application materials through EERE eXCHANGE at <https://eere-eXCHANGE.energy.gov>, EERE’s online application portal.
- Applicants must designate primary and backup points-of-contact in EERE eXCHANGE with whom EERE will communicate to conduct award negotiations. If an application is selected for award negotiations, it is not a commitment to issue an award. It is imperative that the applicant/selectee be responsive during award negotiations and meet negotiation deadlines. Failure to do so may result in cancelation of further award negotiations and rescission of the selection.
- **Unique Entity Identifier (UEI) and System for Award Management (SAM)** - Each applicant (unless the applicant is excepted from those requirements under 2 CFR 25.110) is required to: (1) register in the SAM at <https://www.sam.gov> before submitting an application; (2) provide a valid UEI number in the application; and (3)

*Questions about this FOA? Email [WETOFOA@ee.doe.gov](mailto:WETOFOA@ee.doe.gov)*

*Problems with EERE eXCHANGE? Email [EERE-eXCHANGEsupport@hq.doe.gov](mailto:EERE-eXCHANGEsupport@hq.doe.gov) Include FOA name and number in subject line.*

---

maintain an active SAM registration with current information when the applicant has an active federal award or an application or plan under consideration by a federal awarding agency. DOE may not make a federal award to an applicant until the applicant has complied with all applicable UEI and SAM requirements and, if an applicant has not fully complied with the requirements by the time DOE is ready to make a federal award, DOE will determine that the applicant is not qualified to receive a federal award and use that determination as a basis for making a federal award to another applicant.

**NOTE:** Due to the high number of UEI requests and SAM registrations, entity legal business name and address validations are taking longer than expected to process. Entities should start the UEI and SAM registration process as soon as possible. If entities have technical difficulties with the UEI validation or SAM registration process they should use the [HELP](#) feature on [SAM.gov](#). SAM.gov will address service tickets in the order in which they are received and asks that entities not create multiple service tickets for the same request or technical issue. Additional entity validation resources can be found here: [GSAFSD Tier 0 Knowledge Base - Validating your Entity](#).

# Table of Contents

<b>Table of Contents.....</b>	<b>ii</b>
<b>I. Funding Opportunity Description .....</b>	<b>1</b>
A. Background and Context .....	1
i. Program Purpose .....	1
ii. Technology Space and Strategic Goals .....	3
iii. Teaming Partner List.....	5
B. Topic Area Description .....	6
C. Applications Specifically Not of Interest.....	12
D. Community Benefits Plan .....	12
E. Authorizing Statutes.....	13
<b>II. Award Information .....</b>	<b>13</b>
A. Award Overview .....	13
i. Estimated Funding .....	13
ii. Period of Performance .....	14
iii. New Applications Only .....	14
B. EERE Funding Agreements .....	14
i. Cooperative Agreements.....	14
ii. Funding Agreements with Federally Funded Research and Development Center (FFRDCs) .....	14
<b>III. Eligibility Information .....</b>	<b>15</b>
A. Eligible Applicants .....	15
i. Domestic Entities .....	15
ii. Foreign Entities.....	16
B. Cost Sharing.....	16
i. Legal Responsibility .....	16
ii. Cost Share Allocation.....	17
iii. Cost Share Types and Allowability.....	17
iv. Cost Share Contributions by FFRDCs .....	18
v. Cost Share Verification .....	18
vi. Cost Share Payment.....	18
C. Compliance Criteria .....	19
D. Responsiveness Criteria.....	20
E. Other Eligibility Requirements .....	20
i. Requirements for DOE/NNSA FFRDCs Listed as the Applicant .....	20
ii. Requirements for DOE/NNSA and Non-DOE/NNSA FFRDCs Included as a Subrecipient .....	20
F. Limitation on Number of Concept Papers and Full Applications Eligible for Review .....	21
G. Questions Regarding Eligibility.....	22
<b>IV. Application and Submission Information .....</b>	<b>22</b>
A. Application Process .....	22
i. Additional Information on EERE eXCHANGE .....	23
B. Application Forms .....	23
C. Content and Form of the Concept Paper .....	23
D. Content and Form of the Full Application .....	25
i. Full Application Content Requirements.....	25
ii. Technical Volume (required) .....	26

Questions about this FOA? Email [WETOFOA@ee.doe.gov](mailto:WETOFOA@ee.doe.gov)

Problems with EERE eXCHANGE? Email [EERE-eXCHANGEsupport@hq.doe.gov](mailto:EERE-eXCHANGEsupport@hq.doe.gov) Include FOA name and number in subject line.

iii.	Resumes (required) .....	31
iv.	Letters of Commitment (required) .....	32
v.	Statement of Project Objectives (SOPO) (required) .....	32
vi.	SF-424: Application for Federal Assistance (required) .....	33
vii.	Budget Justification Workbook (required) .....	33
viii.	Summary for Public Release (required) .....	33
ix.	Summary Slide (required) .....	34
x.	Subrecipient Budget Justification (if applicable) .....	34
xi.	Budget for DOE/NNSA FFRDC (if applicable) .....	34
xii.	Authorization for Non-DOE/NNSA or DOE/NNSA FFRDCs (if applicable) .....	35
xiii.	SF-LLL: Disclosure of Lobbying Activities (required) .....	35
xiv.	Waiver Requests (if applicable) .....	35
xv.	Community Benefits Plan (required) .....	36
xvi.	Current and Pending Support (required) .....	37
xvii.	Transparency of Foreign Connections (required) .....	40
xviii.	Potentially Duplicative Funding Notice (required) .....	41
xix.	Locations of Work (required) .....	42
E.	Content and Form of Replies to Reviewer Comments .....	42
F.	Post Selection Information Requests .....	43
G.	Unique Entity Identifier (UEI) and System for Award Management (SAM) .....	44
H.	Submission Dates and Times .....	44
I.	Intergovernmental Review .....	44
J.	Funding Restrictions .....	44
i.	Allowable Costs .....	44
ii.	Pre-Award Costs .....	45
iii.	Performance of Work in the United States (Foreign Work Waiver) .....	46
iv.	Construction .....	46
v.	Foreign Travel .....	46
vi.	Equipment and Supplies .....	46
vii.	Build America Buy America Requirements for Infrastructure Projects .....	47
viii.	Lobbying .....	48
ix.	Risk Assessment .....	48
x.	Invoice Review and Approval .....	49
xii.	Affirmative Action and Pay Transparency Requirements .....	51
xiii.	Foreign Collaboration Considerations .....	51
<b>V.</b>	<b>Application Review Information .....</b>	<b>52</b>
A.	Technical Review Criteria .....	52
i.	Concept Papers .....	52
ii.	Full Applications .....	53
iii.	Criteria for Replies to Reviewer Comments .....	56
B.	Standards for Application Evaluation .....	56
C.	Other Selection Factors .....	57
i.	Program Policy Factors .....	57
D.	Evaluation and Selection Process .....	58
i.	Overview .....	58
ii.	Pre-Selection Interviews .....	58
iii.	Pre-Selection Clarification .....	58
iv.	Recipient Responsibility and Qualifications .....	59
v.	Selection .....	59
E.	Anticipated Notice of Selection and Award Negotiation Dates .....	59

Questions about this FOA? Email [WETOFOA@ee.doe.gov](mailto:WETOFOA@ee.doe.gov)

Problems with EERE eXCHANGE? Email [EERE-eXCHANGESupport@hq.doe.gov](mailto:EERE-eXCHANGESupport@hq.doe.gov) Include FOA name and number in subject line.

<b>VI. Award Administration Information.....</b>	<b>60</b>
A. Award Notices .....	60
i. Ineligible Submissions.....	60
ii. Concept Paper Notifications.....	60
iii. Full Application Notifications.....	60
iv. Applicants Selected for Award Negotiations.....	60
v. Alternate Selection Determinations.....	61
vi. Unsuccessful Applicants .....	61
B. Administrative and National Policy Requirements.....	61
i. Registration Requirements.....	61
ii. Award Administrative Requirements .....	63
iii. Foreign National Participation.....	63
iv. Subaward and Executive Reporting.....	63
v. National Policy Requirements .....	63
vi. Environmental Review in Accordance with National Environmental Policy Act (NEPA) .....	63
vii. Applicant Representations and Certifications .....	64
viii. Statement of Federal Stewardship .....	66
ix. Statement of Substantial Involvement .....	66
x. Intellectual Property Management Plan (IPMP).....	66
xi. Subject Invention Utilization Reporting.....	67
xii. Intellectual Property Provisions.....	67
xiii. Reporting .....	67
xiv. Go/No-Go Review .....	68
xv. Conference Spending.....	69
xvi. Uniform Commercial Code (UCC) Financing Statements .....	69
xvii. Real Property and Equipment .....	69
xviii. Implementation of Executive Order 13798, Promoting Free Speech and Religious Liberty .....	70
xix. Participants and Collaborating Organizations .....	70
xx. Current and Pending Support.....	70
xxi. U.S. Manufacturing Commitments .....	71
xxii. Interim Conflict of Interest Policy for Financial Assistance .....	72
xxiii. Data Management Plan (if applicable) .....	72
xxiv. Fraud, Waste, and Abuse.....	73
xxv. Human Subjects Research .....	74
<b>VII. Questions/Agency Contacts.....</b>	<b>74</b>
<b>VIII. Other Information .....</b>	<b>74</b>
A. FOA Modifications.....	74
B. Government Right to Reject or Negotiate.....	74
C. Commitment of Public Funds .....	75
D. Treatment of Application Information .....	75
E. Evaluation and Administration by Non-Federal Personnel .....	76
F. Notice Regarding Eligible/Ineligible Activities .....	76
G. Notice of Right to Conduct a Review of Financial Capability.....	76
H. Requirement for Full and Complete Disclosure .....	76
I. Retention of Submissions .....	77
J. Title to Subject Inventions.....	77
K. Government Rights in Subject Inventions.....	77
L. Rights in Technical Data .....	78
M. Copyright .....	79
N. Export Control .....	79

*Questions about this FOA? Email [WETOFOA@ee.doe.gov](mailto:WETOFOA@ee.doe.gov)*

*Problems with EERE eXCHANGE? Email [EERE-eXCHANGEsupport@hq.doe.gov](mailto:EERE-eXCHANGESupport@hq.doe.gov) Include FOA name and number in subject line.*

O. Prohibition on Certain Telecommunications and Video Surveillance Services or Equipment .....	79
P. Personally Identifiable Information (PII) .....	80
Q. Annual Independent Audits .....	80
<b>Appendix A – Cost Share Information .....</b>	<b>81</b>
<b>Appendix B – Waiver Requests For: 1. Foreign Entity Participation; and 2. Foreign Work.....</b>	<b>86</b>
<b>Appendix C– Required Use of American Iron, Steel, Manufactured Products, and Construction Materials .....</b>	<b>89</b>
<b>Appendix D – List of Acronyms .....</b>	<b>93</b>
<b>Appendix E – Community Benefits Plan Guidance .....</b>	<b>95</b>

*Questions about this FOA? Email [WETOFOA@ee.doe.gov](mailto:WETOFOA@ee.doe.gov)*

*Problems with EERE eXCHANGE? Email [EERE-eXCHANGESupport@hq.doe.gov](mailto:EERE-eXCHANGESupport@hq.doe.gov) Include FOA name and number in subject line.*

---

---

## I. Funding Opportunity Description

### A. Background and Context

#### i. Program Purpose

The U.S Department of Energy's (DOE) Office of Energy Efficiency and Renewable Energy (EERE) is issuing, on behalf of the Wind Energy Technologies Office (WETO) and Office of Electricity (OE), this Funding Opportunity Announcement (FOA).

WETO invests in wind energy research, development, demonstration, and deployment activities that enable and accelerate the innovations needed to advance offshore, land-based, and distributed wind systems; reduce the cost of wind energy; drive deployment in an environmentally conscious manner; and facilitate the integration of high levels of wind energy with the electric grid.

WETO's goal in renewable systems integration is to remove barriers to enable system planners and operators, via innovation, to capture the economic and environmental benefits of the increasing availability of wind energy, while ensuring overall system reliability, resiliency, and security. This can be accomplished through system planning studies, data, models, tools development, and validation and field demonstrations, coupled with working directly with stakeholders, including utilities, to help ensure adoption of best practices.

OE works to develop new technologies to enhance the infrastructure that brings electricity into our homes, offices, and factories and to improve the federal and state electricity policies and programs that shape electricity system planning and market operations. OE provides national leadership to ensure that the Nation's grid is reliable, resilient, and secure and that the electricity is affordable for everyone.

The Nation's sustained economic prosperity, quality of life, and global competitiveness depend on access to an abundance of secure, reliable, and affordable energy resources. Through a mix of technology and policy solutions, OE is addressing the changing dynamics and uncertainties in which the future electric system will need to operate. OE leverages effective partnerships, solid research, and best practices to support diverse interests in achieving economic, societal, and environmental objectives.

Within OE, the Transformer Resilience and Advanced Components (TRAC) program supports modernization and resiliency of the grid by addressing the unique challenges of grid hardware technologies that are responsible for

---

carrying and controlling electricity from where it is generated to where it is needed.

Analysis of future decarbonization scenarios consistently finds that substantial transmission upgrades will be required to decarbonize the grid by 2035 and be necessary to put the nation on a pathway to a net-zero carbon economy by 2050. Substantial transmission upgrades will also be needed so all Americans can realize the benefits of less-volatile energy costs, reduced climate impacts, and the elimination of air pollution from fossil fuel power plants.

Building a clean and equitable energy economy and addressing the climate crisis is a top priority of the Biden Administration. This FOA supports the administration goals laid out above by supporting a solution to address transmission challenges faced by the nation's grid.

This FOA will advance the Biden Administration's goals to achieve carbon pollution-free electricity by 2035 and to "deliver an equitable, clean energy future, and put the United States on a path to achieve net-zero emissions, economy-wide, by no later than 2050"<sup>1</sup> to the benefit of all Americans. The U.S. Department of Energy is committed to pushing the frontiers of science and engineering, catalyzing clean energy jobs through research, development, demonstration, and deployment (RDD&D), and ensuring environmental justice and inclusion of underserved communities.

The research and development (R&D) activities to be funded under this FOA will support the government-wide approach to the climate crisis by driving the innovation that can lead to the deployment of clean energy technologies, which are critical for climate protection. Specifically, this FOA will invest in R&D to support continued innovation and cost reduction for high-voltage direct current (HVDC) voltage-source converter (VSC) transmission systems. This investment is intended to enable future grid upgrades required to integrate increasing renewable energy generation on to the grid, both onshore and offshore.

Rapid deployment at scale for wind and other renewable resources requires cost-effective transmission solutions.<sup>2</sup> HVDC transmission systems are an effective technology<sup>3</sup> both on land and offshore to accomplish this deployment. Some of the highest quality wind resources<sup>4</sup> in the United States are located offshore. The Administration has set a near-term offshore wind deployment goal

---

<sup>1</sup> Executive Order 14008, "Tackling the Climate Crisis at Home and Abroad," January 27, 2021.

<sup>2</sup> [Transmission-Planning-White-Paper.pdf \(esig.energy\)](#)

<sup>3</sup> [Assessing HVDC Transmission for Impacts of Non-Dispatchable Generation \(EIA\)](#)

<sup>4</sup> [Wind Resource Maps and Data | Geospatial Data Science | NREL](#)

*Questions about this FOA? Email [WETOFOA@ee.doe.gov](mailto:WETOFOA@ee.doe.gov)*

*Problems with EERE eXCHANGE? Email [EERE-eXCHANGESupport@hq.doe.gov](mailto:EERE-eXCHANGESupport@hq.doe.gov) Include FOA name and number in subject line.*

---



of 30 gigawatts (GW) by 2030 and achieving it could unlock a pathway to 110 GW by 2050. Along the Atlantic and Pacific coasts, many states have set their own procurement goals<sup>5</sup> for offshore wind development. HVDC transmission can connect large amounts of new geographically diverse variable renewable energy resources that are far from load centers. As a result, HVDC transmission can facilitate achievement of the Administration's goal of 100% carbon-free electricity by 2035.

HVDC<sup>6</sup> currently accounts for only a small fraction of the existing high-voltage transmission lines in the United States. Of the over 240,000 miles<sup>7</sup> of high-voltage power lines, only 2,370 miles or 1% are HVDC. U.S. HVDC lines include four overhead transmission lines<sup>8</sup> built from 1970 to 1986 and three short underwater lines<sup>9</sup> commissioned from 2002 to 2010. Additionally, there are seven High-Voltage Alternating Current (HVAC)-HVDC-HVAC back-to-back converter stations along the eastern-western interconnect<sup>10</sup> boundary from Montana to New Mexico. Five of these were built between 1977 and 1988 and two were added in 2003–2005. While HVDC has not been a significant part of U.S. grid development since the 1970 and 1980s, several large HVDC projects to deliver renewable generation to load centers are in various phases of planning<sup>11</sup> and construction.<sup>12</sup>

In addition to planning and siting challenges, cost is a critical barrier to widespread adoption and deployment of HVDC systems. Currently, HVDC system cost is driven by the converter substation given its increased complexity compared to HVAC systems. This FOA aims to address this barrier by investing in innovative solutions to reduce the cost of HVDC VSC technology.

## ii. **Technology Space and Strategic Goals**

This FOA seeks to address the significant cost of HVDC systems for transmission applications. Applications submitted for this FOA aim to kickstart DOE's HVDC cost reduction effort as described below.

---

<sup>5</sup> Chapter 2, [Offshore Wind Market Report: 2022 Edition \(energy.gov\)](#)

<sup>6</sup> [List of HVDC Projects - North America](#)

<sup>7</sup> [Energy-2021.pdf \(infrastructurereportcard.org\)](#)

<sup>8</sup> Pacific DC Intertie, Square Butte, Coal Creek to Dickson, and Intermountain Power Project.

<sup>9</sup> Cross Sound, Neptune, and TransBay

<sup>10</sup> [Interconnections Seam Study | Energy Analysis | NREL](#)

<sup>11</sup> VT: <http://necplink.com/>, IA-IL: <https://soogreen.com/>, WY-NV: <http://transwestexpress.net/>, IA-IL: <https://icc.illinois.gov/industry-projects/rock-island-clean-line-project>, KS-IN: <https://grainbeltexpress.com/>, NY: <https://www.cleanpathny.com/>, [About the Project | Sunrise Wind \(sunrisewindny.com\)](#)

<sup>12</sup> [Project Overview - TDI CHPEXpress](#)

---

HVDC technology is a key enabler for large scale deployment of offshore wind as well as land-based renewable generation. DOE has set the groundwork for continued investment in this space.

As part of the [Building a Better Grid Initiative](#), DOE and the Bureau of Ocean Energy Management (BOEM) hosted a series of Atlantic Offshore Wind transmission scoping calls and convening workshops throughout 2021–2023. The associated action plan’s [preliminary findings](#) include a recommendation for HVDC standardization and interoperability to promote a multi-terminal HVDC (MTDC) system transmission solution. WETO’s [Atlantic Offshore Wind Transmission Study](#) and the DOE Grid Deployment Office’s [National Transmission Planning Study](#) analyze future transmission systems that incorporate established HVDC technology. Additionally, the studies incorporate MTDC given projections that a high Technology Readiness Level will be available soon.

In May 2022, WETO and OE co-hosted a three-day HVDC Workshop that brought together key stakeholders to both discuss the current state-of-the-art of HVDC systems and identify gaps in the research that need to be filled to advance the technology to incentivize broad deployment. Some of the critical gaps identified include the development and advancement of standards to aid in the manufacturability and interoperability of HVDC systems, the R&D of wide bandgap semiconductor devices and other technologies to increase the power capacity of the technology, and the improvement of HVDC circuit breakers for fault protection on the HVDC system.

The HVDC workshop informed Topic Area (TA) 1 (High-Voltage Direct Current for Offshore Wind Transmission) of WETO’s [DE-FOA-0002828](#) (Bipartisan Infrastructure Law (BIL) FOA to Address Key Deployment Challenges for Offshore, Land-Based, and Distributed Wind) that was released in December of 2022. Relevant subtopics under TA 1 included HVDC standardization and benchmark system development (TA 1a), MTDC basic controls and functional requirements development (TA 1b), and curriculum creation for education and workforce development (TA 1c). OE also released a [HVDC American-Made Prize](#) in March 2023 to promote “new innovative solutions to technical challenges in HVDC through the development of new hardware, controls, and advanced concepts.”

In the [relevant House Report to the Consolidated Appropriations Act, 2023](#), DOE was directed to initiate a HVDC “moonshot” initiative to reduce the cost of HVDC technology. This directive prompted targeted information gathering and another stakeholder workshop held on May 10<sup>th</sup>, 2023, to collect baseline cost figures and barriers to widespread adoption of HVDC systems. Through these activities, DOE established a [HVDC COst REDuction \(CORE\) Initiative](#) to reduce the

---

combined capital, operating, and maintenance cost of VSC HVDC systems by 35% by 2035. The target annual levelized cost of HVDC converter substations would be \$210/MW/kV by 2035.

Building on the knowledge gained from the previous workshops and studies, this FOA seeks to expand on the various HVDC-related activities led by DOE and is the next phase of HVDC investment focused on voltage-source converter (VSC) technologies. The goal of this FOA is to increase R&D in VSC substations in support of the broader HVDC CORE initiative.

A detailed technical description of the specific Topic Area is provided in the sections that follow.

### **iii. Teaming Partner List**

DOE is compiling a Teaming Partner List to facilitate the formation of project teams for this FOA. The Teaming Partner List allows organizations that may wish to participate on a project to express their interest to other possible applicants and to explore potential partnerships.

The Teaming Partner List will be available on EERE eXCHANGE and will be regularly updated to reflect new teaming partners who provide their organization's information.

**SUBMISSION INSTRUCTIONS:** View the Teaming Partner List by visiting the EERE eXCHANGE homepage and clicking on "Teaming Partners" within the left-hand navigation pane. This page allows users to view published Teaming Partner Lists. To join the Teaming Partner List, submit a request within eXCHANGE. Select the appropriate Teaming Partner List from the drop-down menu and fill in the following information: Investigator Name, Organization Name, Organization Type, Topic Area, Background and Capabilities, Website, Contact Address, Contact Email, and Contact Phone.

**DISCLAIMER:** By submitting a request to be included on the Teaming Partner List, the requesting organization consents to the publication of the above-referenced information. By facilitating the Teaming Partner List, DOE is not endorsing, sponsoring, or otherwise evaluating the qualifications of the individuals and organizations that are identifying themselves for placement on this Teaming Partner List. DOE will not pay for the provision of any information, nor will it compensate any applicants or requesting organizations for the development of such information.

---

## B. Topic Area Description

There are two main categories of HVDC converters: line-commutated converters (LCC) and voltage-source converters (VSC).

LCC technology is mature with a rich technical history. It has been enabled by thyristor switches since the 1960s<sup>13</sup> and is utilized when high power capacity is required. LCCs require a connection to an inertia-strong, existing alternating current (AC) grid to operate effectively and, thus, do not exhibit grid-forming capabilities.

Technologies with grid-forming capabilities can control important characteristics of the grid such as voltage and frequency. They can also effectively kick start electricity flow from generating sources during a black out (also known as black start).<sup>14</sup> As the grid transitions away from a reliance on the inertia of rotating machines, the grid strength is reduced and grid forming capabilities are necessary for the effective operation of the grid.

VSCs were developed approximately 30 years after the first thyristor-enabled LCC.<sup>15</sup> They are enabled by Insulated Gate Bipolar Transistors (IGBTs) and can turn on and off through converter controls, meaning that they exhibit black start and other grid-forming capabilities. VSCs are also the preferred choice to establish a multi-terminal HVDC (MTDC) system, given that current can more easily flow in both directions in a VSC HVDC system. MTDC networks are critical to create efficient and reliable networks for onshore and offshore energy transmission. Hence, this funding opportunity will focus on innovative, cost-reduction solutions for VSC systems.

[Figure 1](#) shows a schematic of a generic, multi-terminal HVDC VSC system. Given the complexity and breadth of technology required to operate a VSC system, this FOA is focused on the converter substation portion of the system as indicated by the yellow box on the figure.

---

<sup>13</sup> [High-Voltage Direct Current: A History of Innovation - Technical Articles \(eepower.com\)](#)

<sup>14</sup> [Research Roadmap on Grid-Forming Inverters \(nrel.gov\)](#)

<sup>15</sup> [High-Voltage Direct Current: A History of Innovation - Technical Articles \(eepower.com\)](#)

Questions about this FOA? Email [WETOFOA@ee.doe.gov](mailto:WETOFOA@ee.doe.gov)

Problems with EERE eXCHANGE? Email [EERE-eXCHANGESupport@hq.doe.gov](mailto:EERE-eXCHANGESupport@hq.doe.gov) Include FOA name and number in subject line.

---

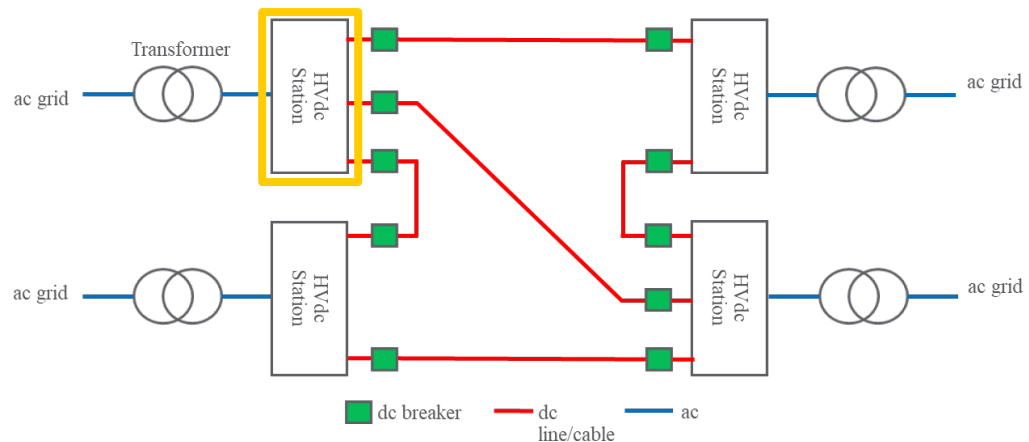

**Figure 1:** A high-level representation of a generic multi-terminal HVDC VSC system. Multi-terminal systems provide increased reliability and redundancy of the system, as well as provide multiple avenues for the electricity to flow based on grid need.

A VSC substation is made up of a 6-valve network that modulates the flow of current to either rectify (AC to DC) or invert (DC to AC) the power being transmitted on the system. Each valve corresponds to the positive and negative components of the 3 phases of AC power. The most common valve type is the modular multi-level converter (MMC). An MMC valve is made of independently-controlled submodules that act as mini converters consisting of switches and capacitors. When connected in series, the submodules provide increased granularity in the output power of the conversion. Figure 2 illustrates the MMC VSC valve configuration.<sup>16</sup>

<sup>16</sup> Li, Wei & Li, Gengyin & Zeng, Rong & Ni, Kai & Hu, Yihua & Wen, Huiqing. (2018). The Fault Detection, Localization, and Tolerant Operation of Modular Multilevel Converters with an Insulated Gate Bipolar Transistor (IGBT) Open Circuit Fault. *Energies*. 11. 837. 10.3390/en11040837.

Questions about this FOA? Email [WETOFOA@ee.doe.gov](mailto:WETOFOA@ee.doe.gov)

Problems with EERE eXCHANGE? Email [EERE-eXCHANGESupport@hq.doe.gov](mailto:EERE-eXCHANGESupport@hq.doe.gov) Include FOA name and number in subject line.

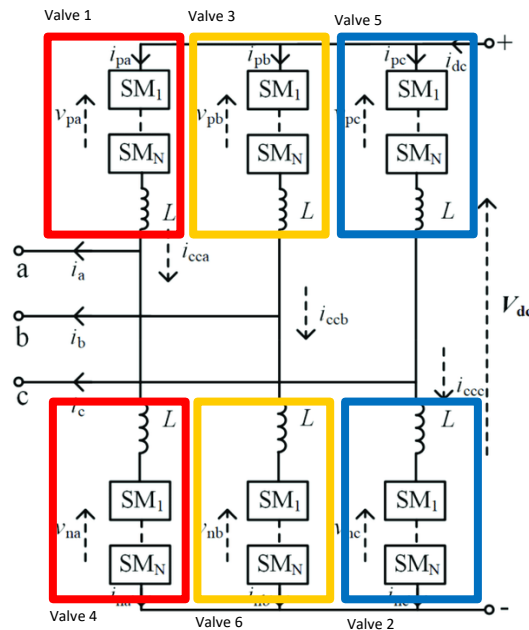

**Figure 2:** A MMC VSC is composed of 6 valves as indicated by the red, yellow, and blue boxes. Each valve has many submodules dependent on the power rating of the converter. Valves 1, 3, & 5 process the positive phases of AC current and valves 2, 4, & 6 process the negative phases.

Submodules are classified as either half-bridge or full-bridge. Half-bridge is typically the preferred configuration based on economic factors, though full-bridge technologies have increased DC fault ride-through capabilities leading to a more reliable system. [Figure 3](#) shows the half-bridge and full-bridge configurations.

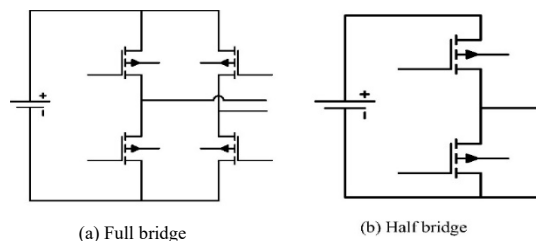

**Figure 3:** The full-bridge and half-bridge configurations are depicted as a and b, respectively. Half-bridge submodules contain half the number of IGBTs as the full bridge, making half-bridge submodules the less expensive configuration by nearly half.

Proposals for this FOA should focus on cost-reduction innovations and solutions for MMC VSC. Below is a list of potential areas for innovation beyond the current state-of-the-art technology.

---

## Targeted Areas for Innovation

### Power Capacity:

The power capacity of a converter substation dictates the maximum level of power generation that can be transmitted from a given source. The highest-rated, operational VSC station clocks in at 3 GW with a voltage rating of 500kV.<sup>17</sup> Additionally, the Transmission System Operator for the Netherlands and most of Germany, has created a standard of a 2 GW, 525 kV system for offshore wind applications.<sup>18</sup>

While these capacities are sufficient for today's needs, increases in power capacity could lead to a more efficient grid in the United States. Higher capacities could allow for increased generation connections to a single substation, thus limiting the number of substations and cost required to transmit the same amount of power.

Power capacity in VSCs is currently limited by silicon (Si) IGBT technology. The material properties of Si, like a bandgap of 1.12eV,<sup>19</sup> limit the current-carrying capacity of the device. Exploring designs that incorporate wide bandgap devices, both existing and developing, with voltage ratings beyond the 4–6 kV range of existing Si devices could increase the power capacity of the system beyond the current state-of-the-art parameters mentioned above. For instance, power can be increased by paralleling power stages; opportunities exist for power converters and circuit topologies that support this scaling.

### Voltage Limit:

The higher the converter voltage, the longer the distance that can be reached by the HVDC transmission line. VSCs still exhibit technology limitations to reaching high voltages beyond 1,100 kV. The limited VSC voltage level is a key factor preventing VSCs from being preferable to LCCs. To improve the voltage limit of VSCs, devices and converter topologies could be investigated to reach higher voltages. Explorations in this space could include, but are not limited to, developments of converter architectures (such as MMC) with a higher number of viable levels, as well as hybrid architectures based on thyristors and IGBTs that can lead to higher voltages.

---

<sup>17</sup> [Zhangbei VSC-HVDC Power Transmission Project, China \(nsenergybusiness.com\)](http://nsenergybusiness.com)

<sup>18</sup> [The 2GW Program | TenneT](#)

<sup>19</sup> [What is a wide-band-gap semiconductor? | Toshiba Electronic Devices & Storage Corporation | Americas – United States \(semicon-storage.com\)](#)

Questions about this FOA? Email [WETOFOA@ee.doe.gov](mailto:WETOFOA@ee.doe.gov)

Problems with EERE eXCHANGE? Email [EERE-eXCHANGESupport@hq.doe.gov](mailto:EERE-eXCHANGESupport@hq.doe.gov) Include FOA name and number in subject line.

---

---

### Size & Power Density:

Offshore substations currently range in size from 200 to 400 feet long, 140 to 350 feet wide, and 80 to 300 feet high.<sup>20</sup> That's larger than a football field. On land, the footprint of the converter substation can range from 2 to 3 acres.<sup>21</sup> Substations of this size require large plots of land, which can be costly and location-prohibitive. The construction and installation of such large structures can also be resource and cost-prohibitive, especially when installing in the ocean.

Decreasing the size of converter substations or increasing the power density of converter substations could reduce overall system costs. Potential areas for size reduction and/or increased power density include, but are not limited to, the use of wide band gap devices, better thermal management solutions, more compact mechanical components, tighter integration with passives and packaging, and better understanding of broader system interactions.

### Lifespan & Reliability:

A typical HVDC converter has an approximate lifespan of 25 years.<sup>22</sup> This is mostly based on the lifespan of the power electronics that make up the system. Exploring design innovations that could extend the life of the power electronic components within the converter past 25 years could reduce overall system lifetime cost. Additionally, exploring opportunities to decrease the failure rate of the power electronic components could lead to increased reliability and reduced operating and maintenance costs of the system.

### Application Qualities:

- Applicants are required to:
  - Describe the current state-of-the-art and the baseline on which the proposed design will improve;
  - Propose an innovative, manufacturable HVDC VSC design (320 kV DC and greater) that exhibits one or more of the following (not an exhaustive list):
    - Increase overall power density of a standard VSC HVDC converter without increasing the cost per MW,
    - Incorporate wide bandgap semiconductors into converter designs,
    - Address device and module thermal management challenges,
    - Include novel component-level changes within the HVDC converter: Filters, capacitors, etc.,

---

<sup>20</sup> [HVDC Cooling Systems White Paper \(boem.gov\)](https://www.boem.gov/hvdc-cooling-systems-white-paper)

<sup>21</sup> [230131\\_Astoria-HVDC-Converter-Station-EMCP-Narrative.pdf \(chpexpress.com\)](#), [TBC Project Presentation to CAISO 041807c.ppt](#)

<sup>22</sup> REPORT TO BE PUBLISHED

*Questions about this FOA? Email [WETOFOA@ee.doe.gov](mailto:WETOFOA@ee.doe.gov)*

*Problems with EERE eXCHANGE? Email [EERE-eXCHANGESupport@hq.doe.gov](mailto:EERE-eXCHANGESupport@hq.doe.gov) Include FOA name and number in subject line.*

---



- 
- Incorporate holistic packaging solutions to manage higher power, higher voltages, and higher operating temperatures, and/or
      - Improve the reliability and lifespan of the technology;
    - Through simulation, emulation, or other analytic approaches, validate that the proposed design(s) can achieve at least 10% of performance improvements in a real-world adjacent scenario as compared to the baseline established;
    - Provide a cost breakdown of how the innovation will reduce overall lifetime HVDC system costs; and
    - Develop a plan to kickstart the next phase of development for the technology if the design is deemed feasible.
  - Applications are highly encouraged to:
    - Develop a scalable prototype at component or subcomponent level where applicable; and
    - Incorporate considerations for offshore wind substations including, but not limited to:
      - Designs that address size & platform constraints,
      - Designs that address offshore specific cost constraints, and
      - Designs that address unique cooling constraints
  - Project Team:
    - Provide a description of the project team with clear descriptions of each team member's role in the project. WETO and OE emphasize increasing diversity of research staff, increasing diversity of voices in research design, and increasing quantification and emphasis on supporting underserved communities.
    - It is preferred that the project team include Principal Investigators from multiple research organizations and include academic representation, where strong consideration should be appropriately given to Minority Serving Institutions.
    - Include relevant industry members from one or more of the following groups: original equipment manufacturers, consultants, electric utilities, and/or system operators. Teaming partnerships are highly recommended.
    - Include letters of support clearly indicating each team member or advisor's role in the proposed project and the support of their organization. See section IV.D.iv. for more information.
  - Broadened Impact:
    - Include with proposals an expected technical stakeholder inclusion plan for project development and an expected communication and outreach plan upon conclusion of the project.
  - Budget Periods:

- The proposed project performance period will be up to 36 months. Depending on the complexity of the project proposed, there may be up to three budget periods and at least two will be required. Projects including just the design criteria should be broken into two budget periods while projects including design and prototyping should be broken into three budget periods.
- There will be formal Go/No-Go decision points between each Budget Period. Funding for future Budget Periods will depend on the results of these Go/No-Go decisions, which will be based in part on the accomplishment of technical milestones during the previous phase as well as the likelihood of success in achieving the objectives of the next phase. Specific criteria for these Go/No-Go decisions will be determined prior to award.

All work for projects selected under this FOA must be performed in the United States. See Section IV.J.iii. and Appendix B.

### **C. Applications Specifically Not of Interest**

The following types of applications will be deemed nonresponsive and will not be reviewed or considered (See Section III.D. of the FOA):

- Applications that fall outside the technical parameters described in Sections I.A. and I.B. of the FOA.
- Applications for proposed technologies that are not based on sound scientific principles (e.g., violates the laws of thermodynamics).
- Applications that propose designs for LCC technology
- Applications that propose designs for or improvements to semiconductor devices and dielectric and magnetic materials
- Applications that propose designs for HVDC lines, cables, and breakers
- Applications that propose designs for HVAC equipment

### **D. Community Benefits Plan**

DOE is committed to investing in research and development (R&D) innovations that deliver benefits to the American public and lead to commercialization of technologies and products that foster sustainable, resilient, and equitable access to clean energy. Further, DOE is committed to supporting the development of more diverse, equitable, inclusive, and accessible workplaces to help maintain the nation's leadership in science and technology.

To support the goal of building a clean and equitable energy economy, projects funded under this FOA are expected to (1) advance diversity, equity, inclusion and accessibility (DEIA); (2) contribute to energy equity; and (3) invest in America's workforce. To ensure these objectives are met, applications must include a Community Benefits Plan (CBP) that addresses the three objectives stated above.

*Questions about this FOA? Email [WETOFOA@ee.doe.gov](mailto:WETOFOA@ee.doe.gov)*

*Problems with EERE eXCHANGE? Email [EERE-eXCHANGESupport@hq.doe.gov](mailto:EERE-eXCHANGESupport@hq.doe.gov) Include FOA name and number in subject line.*

---

See Section IV.D.xv. and Appendix E for the more information on the Community Benefits Plan content requirements.

## E. Authorizing Statutes

The programmatic authorizing statute(s) are the DOE Organization Act (Public Law 95-91), as amended (42 U.S.C. § 7101., et seq.); Energy Policy Act of 2005 (Pub. L. 109-58), Title IX, Subtitle B, § 925, as amended (42 U.S.C. § 16215); and Energy Policy Act of 2005(Pub. L. 109-58), § 936, as added by Energy Act of 2020 (Pub. L. 116-260), Div. Z, Title VIII, § 8004(b) (42 U.S.C. § 16236).

Awards made under this announcement will fall under the purview of 2 CFR Part 200 as amended by 2 CFR Part 910.

## II. Award Information

### A. Award Overview

#### i. Estimated Funding

EERE expects to make a total of approximately \$10M of federal funding available for new awards under this FOA, subject to the availability of appropriated funds. EERE anticipates making approximately 3-4 awards under this FOA. EERE may issue one, multiple, or no awards. Individual awards may vary between \$2.5M and \$3.3M.

Topic Area Title	Anticipated Number of Awards	Anticipated Minimum Award Size for Any One Individual Award (Fed Share)	Anticipated Maximum Award Size for Any One Individual Award (Fed Share)	Approximate Total Federal Funding Available for All Awards	Anticipated Period of Performance (months)	Anticipated number of Budget Period(s)
Innovative Designs for HVDC VSC Technology	3-4	\$2.5M	\$3.3M	\$10M	36	2-3

EERE may establish more than one budget period for each award and fund only the initial budget period(s). Funding for all budget periods, including the initial budget period, is not guaranteed.

**ii. Period of Performance**

EERE anticipates making awards that will run from 2 to 3 years in length, comprised of one or more budget periods. Project continuation will be contingent upon several elements, including satisfactory performance and Go/No-Go decision. For a complete list and more information on the Go/No-Go review, see Section VI.B.xiv.

**iii. New Applications Only**

EERE will accept only new applications under this FOA. EERE will not consider applications for renewals of existing EERE-funded awards through this FOA.

**B. EERE Funding Agreements**

Through cooperative agreements and other similar agreements, EERE provides financial and other support to projects that have the potential to realize the FOA objectives. EERE does not use such agreements to acquire property or services for the direct benefit or use of the U.S. government.

**i. Cooperative Agreements**

EERE generally uses cooperative agreements to provide financial and other support to prime recipients.

Through cooperative agreements, EERE provides financial or other support to accomplish a public purpose of support or stimulation authorized by federal statute. Under cooperative agreements, the government and prime recipients share responsibility for the direction of projects.

EERE has substantial involvement in all projects funded via cooperative agreement. See Section VI.B.ix. of the FOA for more information on what substantial involvement may involve.

**ii. Funding Agreements with Federally Funded Research and Development Center (FFRDCs)<sup>23</sup>**

In most cases, FFRDCs are funded independently of the remainder of the project team. The FFRDC then executes an agreement with any non-FFRDC project team members to arrange work structure, project execution, and any other matters. Regardless of these arrangements, the entity that applied as the prime recipient for the project will remain the prime recipient for the project. See Sections III.E.i and III.E.ii.

---

<sup>23</sup> Federally Funded Research and Development Centers (FFRDC) - FFRDCs are public-private partnerships that conduct research for the U.S. government. A listing of FFRDCs can be found at <http://www.nsf.gov/statistics/ffrdclist/>.

Questions about this FOA? Email [WETOFOA@ee.doe.gov](mailto:WETOFOA@ee.doe.gov)  
Problems with EERE eXCHANGE? Email [EERE-eXCHANGESupport@hq.doe.gov](mailto:EERE-eXCHANGESupport@hq.doe.gov) Include FOA name and number in subject line.

---

### **III. Eligibility Information**

To be considered for substantive evaluation, an applicant's submission must meet the criteria set forth below. If the application does not meet these eligibility requirements, it will be considered ineligible and removed from further evaluation.

#### **A. Eligible Applicants**

##### **i. Domestic Entities**

The proposed prime recipient and subrecipient(s) must be domestic entities. The following types of domestic entities are eligible to participate as a prime recipient or subrecipient of this FOA:

1. Institutions of higher education;
2. For-profit entities;
3. Nonprofit entities; and
4. State and local governmental entities, and Indian tribes.

To qualify as a domestic entity, the entity must be organized, chartered or incorporated (or otherwise formed) under the laws of a particular state or territory of the United States; have majority domestic ownership and control; and have a physical place of business in the United States.

DOE/NNSA FFRDCs are eligible to apply for funding as a prime recipient or subrecipient.

Non-DOE/NNSA FFRDCs are eligible to participate as a subrecipient but are not eligible to apply as a prime recipient.

Federal agencies and instrumentalities (other than DOE) are eligible to participate as a subrecipient but are not eligible to apply as a prime recipient.

Entities banned from doing business with the U.S. government such as entities debarred, suspended, or otherwise excluded from or ineligible for participating in federal programs are not eligible.

Nonprofit organizations described in Section 501(c)(4) of the Internal Revenue Code of 1986 that engaged in lobbying activities after December 31, 1995, are not eligible to apply for funding.

---

**ii. Foreign Entities**

In limited circumstances, EERE may approve a waiver to allow a foreign entity to participate as a prime recipient or subrecipient. A foreign entity may submit a Full Application to this FOA, but the Full Application must be accompanied by an explicit written waiver request. Likewise, if the applicant seeks to include a foreign entity as a subrecipient, the applicant must submit a separate explicit written waiver request in the Full Application for each proposed foreign subrecipient.

Appendix B lists the information that must be included in a foreign entity waiver request. The applicant does not have the right to appeal EERE's decision concerning a waiver request.

**B. Cost Sharing**

Applicants are bound by the cost share proposed in their Full Applications if selected for award negotiations.

The cost share must be at least 20% of the total project costs<sup>24</sup> for research and development projects.<sup>25</sup> The cost share must come from non-federal sources unless otherwise allowed by law.

To help applicants calculate proper cost share amounts, EERE has included a cost share information sheet and sample cost share calculation as Appendix A to this FOA.

**i. Legal Responsibility**

Although the cost share requirement applies to the project as a whole, including work performed by members of the project team other than the prime recipient, the prime recipient is legally responsible for paying the entire cost share. If the funding agreement is terminated prior to the end of the project period, the prime recipient is required to contribute at least the cost share percentage of total expenditures incurred through the date of termination.

The prime recipient is solely responsible for managing cost share contributions by the project team and enforcing cost share obligation assumed by project team members in subawards or related agreements.

---

<sup>24</sup> Total project costs is the sum of the government share, including FFRDC costs if applicable, and the recipient share of project costs.

<sup>25</sup> Energy Policy Act of 2005, Pub. L. 109-58, sec. 988. Also see 2 CFR 200.306 and 2 CFR 910.130 for additional cost sharing requirements.

---

**ii. Cost Share Allocation**

Each project team is free to determine how best to allocate the cost share requirement among the team members. The amount contributed by individual project team members may vary, as long as the cost share requirement for the entire project is met.

**iii. Cost Share Types and Allowability**

Every cost share contribution must be allowable under the applicable federal cost principles, as described in Section IV.J.i. of the FOA. In addition, cost share must be verifiable upon submission of the Full Application. Cost share may be provided in the form of cash or cash equivalents, or in-kind contributions. Cost share must come from non-federal sources (unless otherwise allowed by law), such as project participants, state or local governments, or other third-party financing. Federal financing, such as DOE Loan Guarantee, cannot be leveraged by applicants to provide the required cost share or otherwise support the same scope that is proposed under a project.

Cost share may be provided by the prime recipient, subrecipients, or third parties (entities that do not have a role in performing the scope of work). Vendors/contractors may not provide cost share. Any partial donation of goods or services is considered a discount and is not allowable.

Cash contributions include but are not limited to personnel costs, fringe costs, supply and equipment costs, indirect costs and other direct costs.

In-kind contributions are those where a value of the contribution can be readily determined, verified and justified but where no actual cash is transacted in securing the good or service comprising the contribution. Allowable in-kind contributions include, but are not limited to: the donation of volunteer time or the donation of space or use of equipment.

Project teams may use funding or property received from state or local governments to meet the cost share requirement, so long as the federal government did not provide the funding to the state or local government.

The recipient may not use any of the following sources to meet its cost share obligations:

- Revenues or royalties from the prospective operation of an activity beyond the project period;
- Proceeds from the prospective sale of an asset of an activity;

- 
- Federal funding or property (e.g., federal grants, equipment owned by the federal government); or
  - Expenditures that were reimbursed under a separate federal program.

Project teams may not use the same cash or in-kind contributions to meet cost share requirements for more than one project or program.

Cost share contributions must be specified in the project budget, verifiable from the prime recipient's records, and necessary and reasonable for proper and efficient accomplishment of the project. As all sources of cost share are considered part of total project cost, the cost share dollars will be scrutinized under the same federal regulations as federal dollars to the project. Every cost share contribution must be reviewed and approved in advance by the Contracting Officer and incorporated into the project budget before the expenditures are incurred.

Applicants are encouraged to refer to 2 CFR 200.306 as amended by 2 CFR 910.130 for additional cost sharing requirements.

**iv. Cost Share Contributions by FFRDCs**

Because FFRDCs are funded by the federal government, costs incurred by FFRDCs generally may not be used to meet the cost share requirement. FFRDCs may contribute cost share only if the contributions are paid directly from the contractor's Management Fee or another non-federal source.

**v. Cost Share Verification**

Applicants are required to provide written assurance of their proposed cost share contributions in their Full Applications.

Upon selection for award negotiations, applicants are required to provide additional information and documentation regarding their cost share contributions. Please refer to Appendix A of the FOA.

**vi. Cost Share Payment**

DOE requires prime recipients to contribute the cost share amount incrementally over the life of the award. Specifically, the prime recipient's cost share for each billing period must always reflect the overall cost share ratio negotiated by the parties (i.e., the total amount of cost sharing on each invoice when considered cumulatively with previous invoices must reflect, at a minimum, the cost sharing percentage negotiated). As FFRDC funding will be provided directly to the FFRDC(s) by DOE, prime recipients will be required to provide project cost share



---

at a percentage commensurate with the FFRDC costs, on a budget period basis, resulting in a higher interim invoicing cost share ratio than the total award ratio.

In limited circumstances, and where it is in the government's interest, the Contracting Officer may approve a request by the prime recipient to meet its cost share requirements on a less frequent basis, such as monthly or quarterly. Regardless of the interval requested, the prime recipient must be up-to-date on cost share at each interval. Such requests must be sent to the Contracting Officer during award negotiations and include the following information: (1) a detailed justification for the request; (2) a proposed schedule of payments, including amounts and dates; (3) a written commitment to meet that schedule; and (4) such evidence as necessary to demonstrate that the prime recipient has complied with its cost share obligations to date. The Contracting Officer must approve all such requests before they go into effect.

### **C. Compliance Criteria**

All applicant submissions must:

- Comply with the applicable content and form requirements listed in Section IV. of the FOA;
- Include all required documents;
- Be uploaded and submitted to EERE eXCHANGE <https://eere-eXCHANGE.energy.gov>; and
- Be submitted by the deadline stated in the FOA.

EERE will not review or consider submissions submitted through means other than EERE eXCHANGE, submissions submitted after the applicable deadline, or incomplete submissions.

**Applicants are strongly encouraged to submit their Concept Papers, Full Applications, and Replies to Reviewer Comments at least 48 hours in advance of the submission deadline.** Under normal conditions (i.e., at least 48 hours before the submission deadline), applicants should allow at least one hour to submit a Concept Paper, Full Application, or Reply to Reviewer Comments. Once the Concept Paper, Full Application, or Reply to Reviewer Comments is submitted in EERE eXCHANGE, applicants may revise or update that submission until the expiration of the applicable deadline. If changes are made to any of these documents, the applicant must resubmit the Concept Paper, Full Application, or Reply to Reviewer Comments before the applicable deadline. EERE will not extend the submission deadline for applicants that fail to submit required information by the applicable deadline due to server/connection congestion.

---

## D. Responsiveness Criteria

All Applications Specifically Not of Interest as described in Section I.C. of the FOA, are deemed nonresponsive and are not reviewed or considered.

## E. Other Eligibility Requirements

### i. Requirements for DOE/NNSA FFRDCs Listed as the Applicant

A DOE/NNSA FFRDC is eligible to apply for funding under this FOA if its cognizant Contracting Officer provides written authorization and this authorization is submitted with the application.

The following wording is acceptable for the authorization:

Authorization is granted for the Laboratory to participate in the proposed project. The work proposed for the Laboratory is consistent with or complementary to the missions of the Laboratory, and will not adversely impact execution of the DOE assigned programs at the Laboratory.

If a DOE/NNSA FFRDC is selected for award negotiation, the proposed work will be authorized under the DOE work authorization process and performed under the laboratory's Management and Operating (M&O) contract.

### ii. Requirements for DOE/NNSA and Non-DOE/NNSA FFRDCs Included as a Subrecipient

DOE/NNSA and non-DOE/NNSA FFRDCs may be proposed as a subrecipient on another entity's application subject to the following guidelines:

#### a. Authorization for non-DOE/NNSA FFRDCs

The federal agency sponsoring the FFRDC must authorize in writing the use of the FFRDC on the proposed project and this authorization must be submitted with the application. The use of a FFRDC must be consistent with its authority under its award.

#### b. Authorization for DOE/NNSA FFRDCs

The cognizant Contracting Officer for the FFRDC must authorize in writing the use of the FFRDC on the proposed project and this authorization must be submitted with the application. The following wording is acceptable for this authorization:

Authorization is granted for the Laboratory to participate in the proposed project. The work proposed for the Laboratory is

*Questions about this FOA? Email [WETOFOA@ee.doe.gov](mailto:WETOFOA@ee.doe.gov)*

*Problems with EERE eXCHANGE? Email [EERE-eXCHANGESupport@hq.doe.gov](mailto:EERE-eXCHANGESupport@hq.doe.gov) Include FOA name and number in subject line.*

---

---

consistent with or complementary to the missions of the Laboratory, and will not adversely impact execution of the DOE assigned programs at the Laboratory.

c. Funding, Cost Share, and Subaward with FFRDCs

The value of and funding for the FFRDC portion of the work will not normally be included in the award. DOE/NNSA FFRDCs participating as a subrecipient on a project will be funded directly through the DOE field work proposal (WP) process. Non-DOE/NNSA FFRDCs participating as a subrecipient will be funded through an interagency agreement with the sponsoring agency. Although the FFRDC portion of the work is excluded from the award, the applicant's cost share requirement will be based on the total cost of the project, including the applicant's, the subrecipient's, and the FFRDC's portions of the project.

Unless instructed otherwise by the DOE Contracting Officer for the DOE award, all FFRDCs are required to enter into a Cooperative Research and Development Agreement<sup>26</sup> (CRADA) or, if the role of the DOE/NNSA FFRDC is limited to technical assistance and intellectual property is not anticipated to be generated from the DOE/NNSA FFRDC's work, a Technical Assistance Agreement (TAA), with at least the prime recipient before any project work begins. Any questions regarding the use of a CRADA or TAA should be directed to the cognizant DOE field intellectual property (IP) counsel.

The CRADA or TAA is used to ensure accountability for project work and provide the appropriate management of IP, e.g., data protection and background IP. The CRADA or TAA must be agreed upon by all parties and submitted to DOE or other sponsoring agency, when applicable, for approval, or submitted to DOE for notice under the Master Scope of Work process, when applicable, using any DOE or other sponsoring agency approved CRADA or TAA template without substantive changes by the time the award is made to the prime recipient.

## **F. Limitation on Number of Concept Papers and Full Applications Eligible for Review**

---

<sup>26</sup> A cooperative research and development agreement is a contractual agreement between a national laboratory contractor and a private company or university to work together on research and development. For more information, see <https://www.energy.gov/gc/downloads/doe-cooperative-research-and-development-agreements>

---

An entity may submit only one Concept Paper and one Full Application to this FOA. If an entity submits more than one Concept Paper and Full Application, EERE will request a determination from the applicant's authorizing representative as to which application should be reviewed. Any other submissions received listing the same entity as the applicant will not be eligible for further consideration. This limitation does not prohibit an applicant from collaborating on other applications (e.g., as a potential subrecipient or partner) so long as the entity is listed as the applicant on only one Concept Paper and one Full Application submitted under this FOA.

## G. Questions Regarding Eligibility

DOE will not make eligibility determinations for potential applicants prior to the date on which applications to this FOA must be submitted. The decision whether to apply in response to this FOA lies solely with the applicant.

# IV. Application and Submission Information

## A. Application Process

The application process includes multiple submission phases: Concept Paper and Full Application. **Only applicants who have submitted an eligible Concept Paper will be eligible to submit a Full Application.**

All submissions must conform to the form and content requirements described below, including maximum page lengths.

- Each must be submitted in Adobe PDF format unless stated otherwise;
- Each must be written in English;
- All pages must be formatted to fit on 8.5" x 11" paper with margins not less than one inch on every side. Use Calibri typeface, a black font color, and a font size of 12-point or larger (except in figures or tables, which may be 10-point font). A symbol font may be used to insert Greek letters or special characters, but the font size requirement still applies. References must be included as footnotes or endnotes in a font size of 10 or larger. Footnotes and endnotes are counted toward the maximum page requirement;
- A **control number** will be issued when an applicant begins the EERE eXCHANGE application process. The control number must be included with all application documents. Specifically, the control number must be prominently displayed on the upper right corner of the header of every page and included in the file name (i.e., *Control Number\_Applicant Name\_Full Application*);
- Page numbers must be included in the footer of every page; and

- Each submission must not exceed the specified maximum page limit, including cover page, charts, graphs, maps, and photographs when printed using the formatting requirements set forth above and single spaced. If applicants exceed the maximum page lengths indicated below, EERE will review only the authorized number of pages and disregard any additional pages.

**i. Additional Information on EERE eXCHANGE**

EERE eXCHANGE is designed to enforce the deadlines specified in this FOA. The “Apply” and “Submit” buttons will automatically disable at the defined submission deadlines.

Applicants who experience technical difficulties with submission PRIOR to the FOA deadline should contact the EERE eXCHANGE helpdesk for assistance ([EERE-eXCHANGESupport@hq.doe.gov](mailto:EERE-eXCHANGESupport@hq.doe.gov)).

**B. Application Forms**

The application forms and instructions are available at [EERE Funding Application and Management Forms](#) and on EERE eXCHANGE. To access these materials on EERE eXCHANGE, go to <https://eere-eXCHANGE.energy.gov> and select the appropriate funding opportunity number.

Note: The maximum file size that can be uploaded to the EERE eXCHANGE website is 50MB. Files larger than 50MB cannot be uploaded, and hence cannot be submitted for review. If a file is larger than 50MB but is still within the maximum page limit specified in the FOA, it must be broken into parts and denoted to that effect. For example:

**TechnicalVolume\_Part\_1**  
**TechnicalVolume\_Part\_2**

**EERE will not accept late submissions that resulted from technical difficulties due to uploading files that exceed 50MB.**

**C. Content and Form of the Concept Paper**

Each Concept Paper must be limited to a single concept or technology. The Concept Paper must conform to the requirements listed below, including the stated page limits.

Section	Page Limit	Description
Cover Page	1 page maximum	The cover page should include the project title, the specific announcement Topic Area being addressed (if applicable), both the technical and business points of contact, names of

*Questions about this FOA? Email [WETOFOA@ee.doe.gov](mailto:WETOFOA@ee.doe.gov)  
Problems with EERE eXCHANGE? Email [EERE-eXCHANGESupport@hq.doe.gov](mailto:EERE-eXCHANGESupport@hq.doe.gov) Include FOA name and number in subject line.*

		all team member organizations, the project location(s), and any statements regarding confidentiality.
<b>Technology Description</b>	3 pages maximum	<p>Applicants are required to describe succinctly:</p> <ul style="list-style-type: none"> <li>• The proposed technology, including its basic operating principles and how it is unique and innovative as compared to the current state of the art technology;</li> <li>• The proposed technology’s target level of performance and those target’s relate to this FOA’s goals (applicants should provide technical data or other support to show how the proposed target could be met);</li> <li>• The current state of the art in the relevant field and application, including key shortcomings, limitations, and challenges;</li> <li>• How the proposed technology will overcome the shortcomings, limitations, and challenges in the relevant field and application;</li> <li>• The potential impact that the proposed project would have on the relevant field and application;</li> <li>• How the proposed location of the proposed project will support technology development and long-term success;</li> <li>• The key technical risks/issues associated with the proposed technology development plan; and</li> <li>• The impact that EERE funding would have on the proposed project.</li> </ul>
<b>Community Benefits Plan</b>	1 page maximum	<p>Applicants are required to succinctly describe their approach to the Community Benefits Plan, addressing the three core elements:</p> <ul style="list-style-type: none"> <li>• Advance diversity, equity, inclusion, and accessibility (DEIA);</li> <li>• Contribute to energy equity; and</li> <li>• Invest in America’s workforce.</li> </ul>
<b>Addendum</b>	1 page maximum	<p>Applicants are required to succinctly describe the qualifications, experience, and capabilities of the proposed project team, including:</p> <ul style="list-style-type: none"> <li>• Whether the Principal Investigator (PI) and project team have the skill and expertise needed to successfully execute the project plan;</li> <li>• Whether the applicant has prior experience which demonstrates an ability to perform tasks of similar risk and complexity;</li> <li>• Whether the applicant has worked together with its teaming partners on prior projects or programs;</li> <li>• Whether the applicant has adequate access to equipment and facilities necessary to accomplish the</li> </ul>

Questions about this FOA? Email [WETOFOA@ee.doe.gov](mailto:WETOFOA@ee.doe.gov)  
 Problems with EERE eXCHANGE? Email [EERE-eXCHANGESupport@hq.doe.gov](mailto:EERE-eXCHANGESupport@hq.doe.gov) Include FOA name and number in subject line.

		<p>effort and/or clearly explain how it intends to obtain access to the necessary equipment and facilities; and</p> <ul style="list-style-type: none"> <li>Applicants may provide graphs, charts, or other data to supplement their Technology Description.</li> </ul>
--	--	------------------------------------------------------------------------------------------------------------------------------------------------------------------------------------------------------------------------------------------------------------------------

EERE makes an independent assessment of each Concept Paper based on the criteria in Section V.A.i. of the FOA. EERE will encourage a subset of applicants to submit Full Applications. Other applicants will be discouraged from submitting a Full Application. See Section VI.A.

## D. Content and Form of the Full Application

Applicants must complete the following application forms found at [EERE Funding Application and Management Forms](#) and on the EERE eXCHANGE website at <https://eere-eXCHANGE.energy.gov/>.

Applicants will have approximately 30 days from receipt of the Concept Paper Encourage/Discourage notification on EERE eXCHANGE to prepare and submit a Full Application. Regardless of the date the applicant receives the Encourage/Discourage notification, the submission deadline for the Full Application remains the date and time stated on the FOA cover page.

All Full Application documents must be marked with the control number issued to the applicant.

### i. Full Application Content Requirements

Each Full Application must be limited to a single concept. Full Applications must conform to the following requirements and must not exceed the stated page limits.

Component	File Format	Page Limit	File Name
Technical Volume (required)	PDF	20	ControlNumber_LeadOrganization_TechnicalVolume
Resumes (required)	PDF	3 pages each	ControlNumber_LeadOrganization_Resumes
Letters of Commitment (required)	PDF	1 page each	ControlNumber_LeadOrganization_LOCs
Statement of Project Objectives (required)	MS Word	10	ControlNumber_LeadOrganization_SOPO
SF-424: Application for Federal Assistance (required)	PDF	n/a	ControlNumber_LeadOrganization_App424
Budget Justification Workbook (required)	MS Excel	n/a	ControlNumber_LeadOrganization_Budget_Justification
Summary/Abstract for Public Release (required)	PDF	1	ControlNumber_LeadOrganization_Summary

Questions about this FOA? Email [WETOFOA@ee.doe.gov](mailto:WETOFOA@ee.doe.gov)

Problems with EERE eXCHANGE? Email [EERE-eXCHANGESupport@hq.doe.gov](mailto:EERE-eXCHANGESupport@hq.doe.gov) Include FOA name and number in subject line.

Summary Slide (required)	MS PowerPoint	1	ControlNumber_LeadOrganization_Slide
Subrecipient Budget Justification (if applicable)	MS Excel	n/a	ControlNumber_LeadOrganization_Subrecipient_Budget_Justification
DOE Work Proposal for FFRDC, if applicable (see DOE O 412.1A, Attachment 2)	PDF	n/a	ControlNumber_LeadOrganization_WP
Authorization from cognizant Contracting Officer for FFRDC (if applicable)	PDF	n/a	ControlNumber_LeadOrganization_FFRDCAuth
SF-LLL Disclosure of Lobbying Activities (required)	PDF	n/a	ControlNumber_LeadOrganization_SF-LLL
Foreign Entity Waiver Requests and Foreign Work Waiver Requests (if applicable)	PDF	n/a	ControlNumber_LeadOrganization_Waiver
Community Benefits Plan (required)	PDF	3	ControlNumber_LeadOrganization_CBP
Current and Pending Support (required)	PDF	n/a	ControlNumber_LeadOrganization_CPS
Transparency of Foreign Connections (required)	PDF	n/a	ControlNumber_LeadOrganization_TFC
Potentially Duplicative Funding Notice (required)	PDF	n/a	ControlNumber_LeadOrganization_PDFN
Locations of Work	MS Excel	n/a	ControlNumber_LeadOrganization_LOW

**Note:** The maximum file size that can be uploaded to the EERE eXCHANGE website is 50MB. See Section IV.B.

EERE provides detailed guidance on the content and form of each component below.

**ii. Technical Volume (required)**

The Technical Volume must conform to the following content and form requirements. This volume must address the technical review criteria as discussed in Section V. of the FOA.

Save the Technical Volume in a single PDF file using the following convention for the title “ControlNumber\_LeadOrganization\_TechnicalVolume”.

Applicants must provide sufficient citations and references to the primary research literature to justify the claims and approaches made in the Technical Volume. However, EERE and reviewers are under no obligation to review cited sources.



The Technical Volume to the Full Application may not be more than 20 pages, including the cover page, table of contents, and all citations, charts, graphs, maps, photos, or other graphics, and must include all information in the table below. The applicant should consider the weighting of each of the technical review criteria (see Section V.A.ii. of the FOA) when preparing the Technical Volume.

The Technical Volume should clearly describe and expand upon information provided in the Concept Paper.

<b>Technical Volume Content Requirements</b>	
<b>SECTION/PAGE LIMIT</b>	<b>DESCRIPTION</b>
<b>Cover Page</b>	The cover page should include the project title, the specific FOA Topic Area being addressed (if applicable), both the technical and business points of contact, names of all team member organizations, names of project managers, Senior/Key Personnel and their organizations, the project location(s), and any statements regarding confidentiality.
<b>Project Overview</b> (Approximately 10% of the Technical Volume)	The Project Overview should contain the following information: <ul style="list-style-type: none"> <li>• <b>Background:</b> The applicant should discuss the background of its organization, including the history, successes, and current research and development status (i.e., the technical baseline) relevant to the technical topic being addressed in the Full Application.</li> <li>• <b>Project Goal:</b> The applicant should explicitly identify the targeted improvements to the baseline technology and the critical success factors in achieving that goal.</li> <li>• <b>DOE Impact:</b> The applicant should discuss the impact that DOE funding would have on the proposed project. Applicants should specifically explain how DOE funding, relative to prior, current, or anticipated funding from other public and private sources, is necessary to achieve the project objectives.</li> </ul>
<b>Technical Description, Innovation, and Impact</b> (Approximately 30% of the Technical Volume)	The Technical Description should contain the following information: <ul style="list-style-type: none"> <li>• <b>Relevance and Outcomes:</b> The applicant should provide a detailed description of the technology or focus area, including the scientific and other principles and objectives that will be pursued during the project. This section should describe the relevance of the proposed project to the goals and objectives of the FOA, including the potential to meet specific DOE technical targets or other relevant performance targets. The applicant should clearly specify the expected outcomes of the project.</li> <li>• <b>Feasibility:</b> The applicant should demonstrate the technical feasibility of the proposed technology and capability of achieving</li> </ul>

Questions about this FOA? Email [WETOFOA@ee.doe.gov](mailto:WETOFOA@ee.doe.gov)  
Problems with EERE eXCHANGE? Email [EERE-eXCHANGESupport@hq.doe.gov](mailto:EERE-eXCHANGESupport@hq.doe.gov) Include FOA name and number in subject line.

	<p>the anticipated performance targets, including a description of previous work done and prior results. This section should also address the project’s access to necessary infrastructure (e.g., transportation, water, electricity transmission), including any use of existing infrastructure, as well as to a skilled workforce.</p> <ul style="list-style-type: none"> <li>• Innovation and Impacts: The applicant should describe the current state-of-the-art in the applicable field, the specific, quantifiable innovation of the proposed technology or focus area, the advantages of proposed technology over current and emerging technologies, and the overall impact on advancing the state-of-the-art/technical baseline if the project is successful.</li> </ul>
<p><b>Workplan</b> (Approximately 40% of the Technical Volume)</p>	<p>The Workplan should include a summary of the Project Objectives, Technical Scope, Work Breakdown Structure (WBS), Milestones, Go/No-Go decision points, and Project Schedule. A detailed SOPO is separately requested. The Workplan should contain the following information:</p> <ul style="list-style-type: none"> <li>• Project Objectives: The applicant should provide a clear and concise (high-level) statement of the goals and objectives of the project as well as the expected outcomes.</li> <li>• Technical Scope Summary: The applicant should provide a summary description of the overall work scope and approach to achieve the objective(s). The overall work scope is to be divided by performance periods that are separated by discrete, approximately annual decision points (see below for more information on Go/No-Go decision points). The applicant should describe the specific expected end result of each performance period, including milestones in the Community Benefits Plan.</li> <li>• WBS and Task Description Summary: The Workplan should describe the work to be accomplished and how the applicant will achieve the milestones, will accomplish the final project goal(s), and will produce all deliverables. The Workplan is to be structured with a hierarchy of performance period (approximately annual), task and subtasks, which is typical of a standard WBS for any project. The Workplan shall contain a concise description of the specific activities to be conducted over the life of the project. The description shall be a full explanation and disclosure of the project being proposed (i.e., a statement such as “we will then complete a proprietary process” is unacceptable). It is the applicant’s responsibility to prepare an adequately detailed task plan to describe the proposed project and the plan for addressing the objectives of this FOA. The summary provided should be consistent with the SOPO. The SOPO will contain a more detailed description of the WBS and tasks.</li> <li>• Milestone Summary: The applicant should provide a summary of appropriate milestones throughout the project to demonstrate success. A milestone may be either a progress measure (which can be activity based) or a Specific, Measurable, Attainable, Realistic,</li> </ul>

Questions about this FOA? Email [WETOFOA@ee.doe.gov](mailto:WETOFOA@ee.doe.gov)

Problems with EERE eXCHANGE? Email [EERE-eXCHANGESupport@hq.doe.gov](mailto:EERE-eXCHANGESupport@hq.doe.gov) Include FOA name and number in subject line.

and Timely (SMART) technical milestone. SMART milestones should be Specific, Measurable, Achievable, Relevant, and Timely, and must demonstrate a technical achievement rather than simply completing a task. Unless otherwise specified in the FOA, the minimum requirement is that each project must have at least one milestone per quarter for the duration of the project with at least one SMART technical milestone per year (depending on the project, more milestones may be necessary to comprehensively demonstrate progress). The applicant should also provide the means by which the milestone will be verified. The summary provided should be consistent with the Milestone Summary Table in the SOPO.

- Go/No-Go Decision Points (See Section VI.B.xiv. for more information on the Go/No-Go Review): The applicant should provide a summary of project-wide Go/No-Go decision points at appropriate points in the Workplan. At a minimum, each project must have at least one project-wide Go/No-Go decision point for each budget period (12 to 18-month period) of the project. See Section VI.B.xiv. The applicant should also provide the specific technical and community benefits plan criteria to be used to evaluate the project at the Go/No-Go decision point. The summary provided should be consistent with the SOPO. Go/No-Go decision points are considered “SMART” and can fulfill the requirement for an annual SMART milestone.
- End of Project Goal: The applicant should provide a summary of the end of project goal(s). At a minimum, each project must have one SMART end of project goal. The summary provided should be consistent with the SOPO.
- Project Schedule (Gantt Chart or similar): The applicant should provide a schedule for the entire project, including task and subtask durations, milestones, and Go/No-Go decision points.
- Buy America Requirements for Infrastructure Projects: Within the first two pages of the Workplan, include a short statement on whether the project will involve the construction, alteration, and/or repair of infrastructure in the United States. See Appendix C for applicable definitions and other information to inform this statement.
- Project Management: The applicant should discuss the team’s proposed management plan, including the following:
  - The overall approach to and organization for managing the work;
  - The roles of each project team member;
  - Any critical handoffs/interdependencies among project team members;

Questions about this FOA? Email [WETOFOA@ee.doe.gov](mailto:WETOFOA@ee.doe.gov)

Problems with EERE eXCHANGE? Email [EERE-eXCHANGESupport@hq.doe.gov](mailto:EERE-eXCHANGESupport@hq.doe.gov) Include FOA name and number in subject line.

	<ul style="list-style-type: none"> <li>○ The technical and management aspects of the management plan, including systems and practices, such as financial and project management practices;</li> <li>○ The approach to project risk management, including a plan for securing a qualified workforce and mitigating risks to project performance including but not limited to community or labor disputes;</li> <li>○ A description of how project changes will be handled;</li> <li>○ If applicable, the approach to Quality Assurance/Control; and</li> <li>○ How communications will be maintained among project team members.</li> <li>● Market Transformation Plan: The applicant should provide a market transformation plan, including the following:             <ul style="list-style-type: none"> <li>○ Identification of target market, competitors, and distribution channels for proposed technology along with known or perceived barriers to market penetration, including a mitigation plan;</li> <li>○ Identification of a product development and/or service plan, commercialization timeline, financing, product marketing, legal/regulatory considerations including intellectual property, infrastructure requirements, data dissemination, and product distribution.</li> </ul> </li> </ul>
<p><b>Technical Qualifications and Resources</b> (Approximately 20% of the Technical Volume)</p>	<p>The Technical Qualifications and Resources should contain the following information:</p> <ul style="list-style-type: none"> <li>● A description of the project team’s unique qualifications and expertise, including those of key subrecipients;</li> <li>● A description of the project team’s existing equipment and facilities, or equipment or facilities already in place on the proposed project site, that will facilitate the successful completion of the proposed project; include a justification of any new equipment or facilities requested as part of the project;</li> <li>● Relevant, previous work efforts, demonstrated innovations, and how these enable the applicant to achieve the project objectives;</li> <li>● The time commitment of the key team members to support the project;</li> <li>● A description of the technical services to be provided by DOE/NNSA FFRDCs, if applicable;</li> <li>● The skills, certifications, or other credentials of the construction and ongoing operations workforce;</li> <li>● For multi-organizational projects, describe succinctly:</li> </ul>

Questions about this FOA? Email [WETOFOA@ee.doe.gov](mailto:WETOFOA@ee.doe.gov)  
 Problems with EERE eXCHANGE? Email [EERE-eXCHANGESupport@hq.doe.gov](mailto:EERE-eXCHANGESupport@hq.doe.gov) Include FOA name and number in subject line.

	<ul style="list-style-type: none"> <li>○ The roles and the work to be performed by the PI and Senior/Key Personnel at the prime and sub levels;</li> <li>○ Business agreements between the applicant and sub;</li> <li>○ How the various efforts will be integrated and managed;</li> <li>○ Process for making decisions on technical direction;</li> <li>○ Publication arrangements;</li> <li>○ Intellectual property issues; and</li> <li>○ Communication plans</li> </ul>
--	------------------------------------------------------------------------------------------------------------------------------------------------------------------------------------------------------------------------------------------------------------------------------------------------------------------------------------------------------------------------------------------------------------------------------------------------------------------------------

### iii. Resumes (required)

A resume provides information reviewers can use to evaluate an individual’s skills, experience, and potential for leadership within the scientific community. Applicants must submit a resume (limited to three pages) for each Principal Investigator and Senior/Key Personnel that includes the following:

1. Contact information;
2. Education and training: Provide name of institution, major/area, degree, and year for undergraduate, graduate, and postdoctoral training;
3. Research and professional experience: Beginning with the current position, list professional/academic positions in chronological order with a brief description. List all current academic, professional, or institutional appointments, foreign or domestic, at the applicant institution or elsewhere, whether or not remuneration is received, and, whether full-time, part-time, or voluntary;
4. Awards and honors;
5. A list of up to 10 publications most closely related to the proposed project. For each publication, identify the names of all authors (in the same sequence in which they appear in the publication), the article title, book or journal title, volume number, page numbers, year of publication, and website address if available electronically. Patents, copyrights, and software systems developed may be provided in addition to or substituted for publications. An abbreviated style such as the Physical Review Letters (PRL) convention for citations (list only the first author) may be used for publications with more than 10 authors;
6. Synergistic activities: List up to five professional and scholarly activities related to the proposed effort; and
7. There should be no lapses in time over the past 10 years or since age 18, whichever period is shorter.

---

As an alternative to a resume, it is acceptable to use the biographical sketch format approved by the National Science Foundation (NSF). The biographical sketch format may be generated by the Science Experts Network Curriculum Vita (SciENCv), a cooperative venture maintained at <https://www.ncbi.nlm.nih.gov/sciencv/>, also available at <https://nsf.gov/bfa/dias/policy/nsfapprovedformats/biosketch.pdf>. The use of a format required by another agency is intended to reduce the administrative burden to researchers by promoting the use of common formats.

Save the resumes in a single PDF file using the following convention for the title "ControlNumber\_LeadOrganization\_Resumes".

#### **iv. Letters of Commitment (required)**

Submit letters of commitment from all entities substantially contributing to the proposed project, all subrecipients, and all third-party cost share providers. An entity is considered substantial if its involvement is critical for project success.

If contributing cost share, the letter must state that the party is committed to providing a specific minimum dollar amount or value of in-kind contributions allocated to cost sharing.

The following information for each third party contributing to cost sharing should be identified: (1) the name of the organization; (2) the proposed dollar amount to be provided; and (3) the proposed cost sharing type – (cash or in-kind contributions). Each letter must not exceed 1 page.

If not contributing cost share, the letter must state that the organization is committed to perform the work as outlined in the application.

Save the letters of commitment in a single PDF file using the following convention for the title "ControlNumber\_LeadOrganization\_LOCs".

#### **v. Statement of Project Objectives (SOPO) (required)**

Applicants must complete a SOPO. A SOPO template is available at: [EERE Funding Application and Management Forms](#). The SOPO, including the Milestone Table, must not exceed 10 pages when printed using standard 8.5" x 11" paper with 1" margins (top, bottom, left, and right) with font not smaller than 12-point (except in figures or tables, which may be 10-point font).

Save the SOPO in a single Microsoft Word file using the following convention for the title "ControlNumber\_LeadOrganization\_SOPO".

---

**vi. SF-424: Application for Federal Assistance (required)**

Applicants must complete the SF-424 Application for Federal Assistance, which is available at: [EERE Funding Application and Management Forms](#). The list of certifications and assurances in Field 21 can be found at <http://energy.gov/management/office-management/operational-management/financial-assistance/financial-assistance-forms>, under Certifications and Assurances. Note: The dates and dollar amounts on the SF-424 are for the complete project period and not just the first project year, first phase or other subset of the project period.

Save the SF-424 in a single PDF file using the following convention for the title “ControlNumber\_LeadOrganization\_424”.

**vii. Budget Justification Workbook (required)**

Applicants must complete the Budget Justification Workbook, available at: [EERE Funding Application and Management Forms](#). Applicants must complete each tab of the Budget Justification Workbook for the project, including all work to be performed by the prime recipient and its subrecipients and contractors. Applicants should include costs associated with required annual audits and incurred cost proposals in their proposed budget documents. The “Instructions and Summary” included with the Budget Justification Workbook will auto-populate as the applicant enters information into the Workbook. Applicants must carefully read the “Instructions and Summary” tab provided within the Budget Justification Workbook.

Save the Budget Justification Workbook in a single Microsoft Excel file using the following convention for the title “ControlNumber\_LeadOrganization\_Budget\_Justification”.

**viii. Summary for Public Release (required)**

Applicants must submit a one-page summary of their project that is suitable for dissemination to the public. It should be a self-contained document that identifies the name of the applicant, the lead project manager/principal investigator(s), the project title, the objectives of the project, a description of the project, including methods to be employed, the potential impact of the project (e.g., benefits, outcomes), major participants (for collaborative projects), and the project’s commitments and goals described in the Community Benefits Plan. This document must not include any proprietary or business-sensitive information as DOE may make it available to the public after selections are made. The summary must not exceed one page when printed using standard 8.5” x 11” paper with 1” margins (top, bottom, left, and right) with font not smaller than 12-point.

---

Save the Summary for Public Release in a single PDF file using the following convention for the title: "ControlNumber\_LeadOrganization\_Summary".

**ix. Summary Slide (required)**

Applicants must provide a single slide summarizing the proposed project. The Summary Slide template is available on EERE eXCHANGE at <https://eere-eXCHANGE.energy.gov/> and must include the following information:

- A technology summary;
- A description of the technology's impact;
- Proposed project goals;
- Any key graphics (illustrations, charts and/or tables);
- The project's key idea/takeaway;
- Topline community benefits;
- Project title, prime recipient, PI, and Senior/Key Personnel information; and
- Requested EERE funds and proposed applicant cost share.

Save the Summary Slide in a single Microsoft PowerPoint file using the following convention for the title "ControlNumber\_LeadOrganization\_Slide".

**x. Subrecipient Budget Justification (if applicable)**

Applicants must provide a separate budget justification for each subrecipient that is expected to perform work estimated to be more than \$250,000 or 25% of the total work effort, whichever is less. The budget justification must include the same justification information described in the "Budget Justification" section above.

Save each subrecipient budget justification in a Microsoft Excel file using the following convention for the title: "ControlNumber\_LeadOrganization\_Subrecipient\_Budget\_Justification".

**xi. Budget for DOE/NNSA FFRDC (if applicable)**

If a DOE/NNSA FFRDC is to perform a portion of the work, the applicant must provide a DOE work proposal (WP) in accordance with the requirements in DOE Order 412.1A, Work Authorization System, Attachment 2, available at: <https://www.directives.doe.gov/directives-documents/400-series/0412.1-BOrder-a-chg1-AdmChg>.

Save the WP in a single PDF file using the following convention for the title "ControlNumber\_LeadOrganization\_WP".



---

**xii. Authorization for Non-DOE/NNSA or DOE/NNSA FFRDCs (if applicable)**

The federal agency sponsoring the FFRDC must authorize in writing the use of the FFRDC on the proposed project and this authorization must be submitted with the application. The use of a FFRDC must be consistent with the contractor's authority under its award.

Save the Authorization in a single PDF file using the following convention for the title "ControlNumber\_LeadOrganization\_FFRDCAuth".

**xiii. SF-LLL: Disclosure of Lobbying Activities (required)**

Recipients and subrecipients may not use any federal funds to influence or attempt to influence, directly or indirectly, congressional action on any legislative or appropriation matters.

Recipients and subrecipients are required to complete and submit SF-LLL, "Disclosure of Lobbying Activities" (<https://www.grants.gov/web/grants/forms/sf-424-individual-family.html>) to ensure that non-federal funds have not been paid and will not be paid to any person for influencing or attempting to influence any of the following in connection with the application:

- An officer or employee of any federal agency;
- A member of Congress;
- An officer or employee of Congress; or
- An employee of a member of Congress.

Save the SF-LLL in a single PDF file using the following convention for the title "ControlNumber\_LeadOrganization\_SF-LLL".

**xiv. Waiver Requests (if applicable)****Foreign Entity Participation**

For projects selected under this FOA, all recipients and subrecipients must qualify as domestic entities. See Section III.A To request a waiver of this requirement, the applicant must submit an explicit waiver request in the Full Application. Appendix B lists the information that must be included in a waiver request.

**Foreign Work Waiver Request**

As set forth in Section IV.J.iii., all work for projects selected under this FOA must be performed in the United States. To request a waiver of this requirement, the

---

applicant must submit an explicit waiver request in the Full Application. Appendix B lists the information that must be included in a foreign work waiver request.

Save the Waivers in a single PDF file using the following convention for the title “ControlNumber\_LeadOrganization\_Waiver”.

**xv. Community Benefits Plan (required)**

The Community Benefits Plan must set forth the applicant’s approach to ensuring the Federal investments advance the following three objectives: (1) DEIA; (2) energy equity; and (3) investing in America’s workforce. The below sections set forth the content requirements for the Community Benefits Plan, which addresses each of these objectives. Applicants must address all three sections.

The applicant’s Community Benefits Plan must include at least one Specific, Measurable, Attainable, Realistic, and Timely (SMART) milestone per budget period to measure progress on the proposed actions. The Community Benefits Plan will be evaluated as part of the technical review process. If a project is selected, EERE will incorporate the Community Benefits Plan into the award and the recipient must implement its Community Benefits Plan when carrying out its project. EERE will evaluate the recipient’s progress throughout the life of the award, including as part of the Go/No-Go review process.

The plan should be specific to the proposed project and not a restatement of an organization’s policies. Applicants should describe the future implications or a milestone-based plan for identifying future implications of their research on energy equity, including, but not limited to, benefits for the U.S. workforce. These impacts may be uncertain, occur over a long period of time, and/or have many factors within and outside the specific proposed research. Applicants are encouraged to describe the influencing factors and the most likely workforce and energy equity implications of the proposed research if the research is successful. While some guidance and example activities are provided in Appendix E, applicants are encouraged to leverage promising practices and develop a plan tailored to their project.

The Community Benefits Plan must not exceed three pages. It must be submitted in PDF format using the following convention name for the title: “ControlNumber\_LeadOrganization\_CBP.” This Plan must address the technical review criterion titled, “Community Benefits Plan.” See Section V. of the FOA.

The Community Benefits Plan must address the following three sections:

**1) Diversity, Equity, Inclusion, and Accessibility:**

To building a clean and equitable energy economy, it is important that there are opportunities for people of all racial, ethnic, socioeconomic and geographic backgrounds, sexual orientation, gender identity, persons with disabilities, and those re-entering the workforce from incarceration. This section of the plan must demonstrate how DEIA is incorporated in the technical project objectives. The plan must identify the specific action the applicant would take that integrates into the research goals and project teams. Submitting an institutional DEIA plan without specific integration into the project will be deemed insufficient.

**2) Energy Equity:**

This section must articulate the applicant's consideration of long-term equity implications of the research. It must identify how the specific project integrates equity considerations into the project design to support equitable outcomes if the innovation is successful. Like cost reductions and commercialization plans, the Community Benefits Plan requires description of the equity implications of the innovation.

**3) Workforce Implications:**

This section must articulate the applicant's consideration of long-term workforce impacts and opportunities of the research. It must identify how the project is designed and executed to include an understanding of the future workforce needs if the innovation is successful.

See Appendix E for more guidance.

**xvi. Current and Pending Support (required)**

Current and pending support is intended to allow the identification of potential duplication, overcommitment, potential conflicts of interest or commitment, and all other sources of support. As part of the application, the principal investigator and all senior/key personnel at the applicant and subrecipient level must provide a list of all sponsored activities, awards, and appointments, whether paid or unpaid; provided as a gift with terms or conditions or provided as a gift without terms or conditions; full-time, part-time, or voluntary; faculty, visiting, adjunct, or honorary; cash or in-kind; foreign or domestic; governmental or private-sector; directly supporting the individual's research or indirectly supporting the individual by supporting students, research staff, space, equipment, or other research expenses. All connections with foreign government-sponsored talent recruitment programs must be identified in current and pending support.

For every activity, list the following items:

- 
- The sponsor of the activity or the source of funding;
  - The award or other identifying number;
  - The title of the award or activity. If the title of the award or activity is not descriptive, add a brief description of the research being performed that would identify any overlaps or synergies with the proposed research;
  - The total cost or value of the award or activity, including direct and indirect costs and cost share. For pending proposals, provide the total amount of requested funding;
  - The award period (start date through end date); and
  - The person-months of effort per year dedicated to the award or activity.

To identify overlap, duplication of effort, or synergistic efforts, append a description of the other award or activity to the current and pending support.

Details of any obligations, contractual or otherwise, to any program, entity, or organization sponsored by a foreign government must be provided on request to either the applicant institution or DOE. Supporting documents of any identified source of support must be provided to DOE on request, including certified translations of any document.

PIs and senior/key personnel must provide a separate disclosure statement listing the required information above regarding current and pending support. Each individual must sign and date their respective disclosure statement and include the following certification statement:

I, [Full Name and Title], certify to the best of my knowledge and belief that the information contained in this Current and Pending Support Disclosure Statement is true, complete, and accurate. I understand that any false, fictitious, or fraudulent information, misrepresentations, half-truths, or omissions of any material fact, may subject me to criminal, civil or administrative penalties for fraud, false statements, false claims or otherwise. (18 U.S.C. §§ 1001 and 287, and 31 U.S.C. §§ 3729-3733 and 3801-3812). I further understand and agree that (1) the statements and representations made herein are material to DOE's funding decision, and (2) I have a responsibility to update the disclosures during the period of performance of the award should circumstances change which impact the responses provided above.

The information may be provided in the format approved by the NSF, which may be generated by the Science Experts Network Curriculum Vita (SciENCv), a cooperative venture maintained at <https://www.ncbi.nlm.nih.gov/sciencv/>, also

*Questions about this FOA? Email [WETOFOA@ee.doe.gov](mailto:WETOFOA@ee.doe.gov)  
Problems with EERE eXCHANGE? Email [EERE-eXCHANGESupport@hq.doe.gov](mailto:EERE-eXCHANGESupport@hq.doe.gov) Include FOA name and number in subject line.*

---

---

available at <https://www.nsf.gov/bfa/dias/policy/nsfapprovedformats/cps.pdf>.

The use of a format required by another agency is intended to reduce the administrative burden to researchers by promoting the use of common formats. If the NSF format is used, the individual must still include a signature, date, and a certification statement using the language included in the paragraph above.

Save the Current and Pending Support in a single PDF file using the following convention for the title "ControlNumber\_LeadOrganization\_CPS".

### **Definitions:**

**Current and pending support** – (a) All resources made available, or expected to be made available, to an individual in support of the individual's RD&D efforts, regardless of (i) whether the source is foreign or domestic; (ii) whether the resource is made available through the entity applying for an award or directly to the individual; or (iii) whether the resource has monetary value; and (b) includes in-kind contributions requiring a commitment of time and directly supporting the individual's RD&D efforts, such as the provision of office or laboratory space, equipment, supplies, employees, or students. This term has the same meaning as the term Other Support as applied to researchers in NSPM-33: For researchers, Other Support includes all resources made available to a researcher in support of and/or related to all of their professional RD&D efforts, including resources provided directly to the individual or through the organization, and regardless of whether or not they have monetary value (e.g., even if the support received is only in-kind, such as office/laboratory space, equipment, supplies, or employees). This includes resource and/or financial support from all foreign and domestic entities, including but not limited to gifts provided with terms or conditions, financial support for laboratory personnel, and participation of student and visiting researchers supported by other sources of funding.

**Foreign Government-Sponsored Talent Recruitment Program** – An effort directly or indirectly organized, managed, or funded by a foreign government, or a foreign government instrumentality or entity, to recruit science and technology professionals or students (regardless of citizenship or national origin, or whether having a full-time or part-time position). Some foreign government-sponsored talent recruitment programs operate with the intent to import or otherwise acquire from abroad, sometimes through illicit means, proprietary technology or software, unpublished data and methods, and intellectual property to further the military modernization goals and/or economic goals of a foreign government. Many, but not all, programs aim to incentivize the targeted individual to physically relocate to the foreign state for the above purpose. Some programs allow for or encourage continued employment at United States research facilities or receipt of federal research funds while concurrently working

*Questions about this FOA? Email [WETOFOA@ee.doe.gov](mailto:WETOFOA@ee.doe.gov)*

*Problems with EERE eXCHANGE? Email [EERE-eXCHANGESupport@hq.doe.gov](mailto:EERE-eXCHANGESupport@hq.doe.gov) Include FOA name and number in subject line.*

---

---

at and/or receiving compensation from a foreign institution, and some direct participants not to disclose their participation to United States entities. Compensation could take many forms including cash, research funding, complimentary foreign travel, honorific titles, career advancement opportunities, promised future compensation, or other types of remuneration or consideration, including in-kind compensation.

**Senior/key personnel** – An individual who contributes in a substantive, meaningful way to the scientific development or execution of a research, development and demonstration (RD&D) project proposed to be carried out with a DOE award.<sup>27</sup>

**xvii. Transparency of Foreign Connections (required)**

Applicants must provide the following as it relates to the proposed recipient and subrecipients. Include a separate disclosure for the applicant and each proposed subrecipient. U.S. National Laboratories, domestic government entities, and institutions of higher education are only required to respond to items 1, 2 and 9, and if applying to serve as the prime recipient, must provide complete responses for project team members that are not U.S. National Laboratories, domestic government entities, or institutions of higher education.

1. Entity name, website address and mailing address;
2. The identity of all owners, principal investigators, project managers, and senior/key personnel who are a party to any *Foreign Government-Sponsored Talent Recruitment Program* of a foreign country of risk (i.e., China, Iran, North Korea, and Russia);
3. The existence of any joint venture or subsidiary that is based in, funded by, or has a foreign affiliation with any foreign country of risk;
4. Any current or pending contractual or financial obligation or other agreement specific to a business arrangement, or joint venture-like arrangement with an enterprise owned by a foreign state or any foreign entity;
5. Percentage, if any, that the proposed recipient or subrecipient has foreign ownership or control;
6. Percentage, if any, that the proposed recipient or subrecipient is wholly or partially owned by an entity in a foreign country of risk;

---

<sup>27</sup> Typically, these individuals have doctoral or other professional degrees, although individuals at the masters or baccalaureate level may be considered Senior/Key Personnel if their involvement meets this definition. Consultants, graduate students, and those with a postdoctoral role also may be considered Senior/Key Personnel if they meet this definition.

Questions about this FOA? Email [WETOFOA@ee.doe.gov](mailto:WETOFOA@ee.doe.gov)

Problems with EERE eXCHANGE? Email [EERE-eXCHANGESupport@hq.doe.gov](mailto:EERE-eXCHANGESupport@hq.doe.gov) Include FOA name and number in subject line.

7. Percentage, if any, of venture capital or institutional investment by an entity that has a general partner or individual holding a leadership role in such entity who has a foreign affiliation with any foreign country of risk;
8. Any technology licensing or intellectual property sales to a foreign country of risk, during the 5-year period preceding submission of the proposal;
9. Any foreign business entity, offshore entity, or entity outside the United States related to the proposed recipient or subrecipient;
10. Complete list of all directors (and board observers), including their full name, citizenship and shareholder affiliation, date of appointment, duration of term, as well as a description of observer rights as applicable;
11. Complete capitalization table for your entity, including all equity interests (including LLC and partnership interests, as well as derivative securities). Include both the number of shares issued to each equity holder, as well as the percentage of that series and all equity on a fully diluted basis. Identify the principal place of incorporation (or organization) for each equity holder. If the equity holder is a natural person, identify the citizenship(s). If the recipient or subrecipient is a publicly traded company, provide the above information for shareholders with an interest greater than 5%;
12. A summary table identifying all rounds of financing, the purchase dates, the investors for each round, and all the associated governance and information rights obtained by investors during each round of financing; and
13. An organization chart to illustrate the relationship between your entity and the immediate parent, ultimate parent, and any intermediate parent, as well as any subsidiary or affiliates. Identify where each entity is incorporated.

DOE reserves the right to request additional or clarifying information based on the information submitted.

Save the Transparency of Foreign Connections information in a single PDF file using the following convention for the title  
"ControlNumber\_LeadOrganization\_TFC."

#### **xviii. Potentially Duplicative Funding Notice (required)**

If the applicant or project team member has other active awards of federal funds, the applicant must determine whether the activities of those awards potentially overlap with the activities set forth in its application to this FOA. If there is a potential overlap, the applicant must notify DOE in writing of the potential overlap and state how it will ensure any project funds (i.e., recipient cost share and federal funds) will not be used for identical cost items under

*Questions about this FOA? Email [WETOFOA@ee.doe.gov](mailto:WETOFOA@ee.doe.gov)  
Problems with EERE eXCHANGE? Email [EERE-eXCHANGESupport@hq.doe.gov](mailto:EERE-eXCHANGESupport@hq.doe.gov) Include FOA name and number in subject line.*

---

multiple awards. Likewise, for projects that receive funding under this FOA, if a recipient or project team member receives any other award of federal funds for activities that potentially overlap with the activities funded under the DOE award, the recipient must promptly notify DOE in writing of the potential overlap and state whether project funds from any of those other federal awards have been, are being, or are to be used (in whole or in part) for one or more of the identical cost items under the DOE award. If there are identical cost items, the recipient must promptly notify the Contracting Officer in writing of the potential duplication and eliminate any inappropriate duplication of funding.

Save the Potentially Duplicative Funding Notice in a single PDF file using the following convention for the title "ControlNumber\_LeadOrganization\_PDFN."

**xix. Locations of Work (required)**

The applicant must complete the supplied template by listing the city, state, and zip code + 4 and State for each location where project work will be performed by the prime recipient or subrecipient(s). Save the completed template as a MS Excel file using the following convention for the title "Control Number\_LeadOrganization\_LOW."

**E. Content and Form of Replies to Reviewer Comments**

EERE will provide applicants with reviewer comments following the evaluation of all eligible Full Applications. Applicants have a brief opportunity to prepare a short Reply to Reviewer Comments (Reply). The Reply must not exceed three pages. If a Reply is more than three pages in length, EERE will review only the first three pages and disregard additional pages. Applicants may use the Reply to respond to one or more comments or to supplement their Full Application. The Reply may include text, graphs, charts, or data.

EERE will post the reviewer comments in EERE eXCHANGE. The expected submission deadline is on the cover page of the FOA; however, it is the applicant's responsibility to monitor EERE eXCHANGE if the expected date changes. The deadline will not be extended for applicants who are unable to timely submit their Reply due to failure to check EERE eXCHANGE or relying on the expected date alone. Applicants should anticipate having approximately three (3) business days to submit a Reply.

Applicants are not required to submit a Reply to Reviewer Comments. EERE will review and consider each eligible Full Application, even if no Reply is submitted or if the Reply is found to be ineligible.



---

## F. Post Selection Information Requests

If selected for award negotiations, EERE reserves the right to require that selected applicants provide additional or clarifying information regarding the application submissions, the project, the project team, the award requirements, and any other matters related to anticipated award. The following is a list of examples of information that may be required:

- Personnel proposed to work on the project and collaborating organizations (See Section VI.B.xix. Participants and Collaborating Organizations);
- Current and Pending Support (See Sections IV.D.xvi. and VI.B.xx. Current and Pending Support);
- An Intellectual Property Management Plan (if applicable) describing how the project team/consortia members will handle intellectual property rights and issues between themselves while ensuring compliance with federal intellectual property laws, regulations, and policies in accordance with Section VI.B.x. Intellectual Property Management Plan;
- A Data Management Plan (if applicable) describing how all research data displayed in publications resulting from the proposed work will be digitally accessible at the time of publications, in accordance with Section VI.B.xxiii.;
- Indirect cost information;
- Other budget information;
- Letters of Commitment from third parties contributing to cost share, if applicable;
- Name and phone number of the Designated Responsible Employee for complying with national policies prohibiting discrimination (See 10 CFR 1040.5);
- Information for the DOE Office of Civil Rights to process assurance reviews under 10 CFR 1040;
- Representation of Limited Rights Data and Restricted Software, if applicable; and
- Environmental Questionnaire.

---

## **G. Unique Entity Identifier (UEI) and System for Award Management (SAM)**

Each applicant (unless the applicant is an individual or federal awarding agency that is excepted from those requirements under 2 CFR 25.110(b) or (c), or has an exception approved by the federal awarding agency under 2 CFR 25.110(d)) is required to: (1) Register in the SAM at <https://www.sam.gov> before submitting an application; (2) provide a valid UEI in the application; and (3) maintain an active SAM registration with current information when the applicant has an active federal award or an application or plan under consideration by a federal awarding agency. DOE may not make a federal award to an applicant until the applicant has complied with all applicable UEI and SAM requirements. If an applicant has not fully complied with the requirements by the time DOE is ready to make a federal award, DOE will determine that the applicant is not qualified to receive a federal award and use that determination as a basis for making a federal award to another applicant.

**NOTE:** Due to the high demand of UEI requests and SAM registrations, entity legal business name and address validations are taking longer than expected to process. Entities should start the UEI and SAM registration process as soon as possible. If entities have technical difficulties with the UEI validation or SAM registration process they should use the [HELP](#) feature on [SAM.gov](#). SAM.gov will work entity service tickets in the order in which they are received and asks that entities not create multiple service tickets for the same request or technical issue. Additional entity validation resources can be found here: [GSAFSD Tier 0 Knowledge Base - Validating your Entity](#).

## **H. Submission Dates and Times**

All required submissions must be submitted in EERE eXCHANGE no later than 5 p.m. ET on the dates provided on the cover page of this FOA.

## **I. Intergovernmental Review**

This FOA is not subject to Executive Order 12372 – Intergovernmental Review of Federal Programs.

## **J. Funding Restrictions**

### **i. Allowable Costs**

All expenditures must be allowable, allocable, and reasonable in accordance with the applicable federal cost principles. Pursuant to 2 CFR 910.352, the cost principles in the Federal Acquisition Regulations (48 CFR 31.2) apply to for-profit

---

entities. The cost principles contained in 2 CFR Part 200, Subpart E apply to all entities other than for-profits.

**ii. Pre-Award Costs**

Applicants selected for award negotiations (selectee) must request prior written approval to charge pre-award costs. Pre-award costs are those incurred prior to the effective date of the federal award directly pursuant to the negotiation and in anticipation of the federal award where such costs are necessary for efficient and timely performance of the scope of work. Such costs are allowable only to the extent that they would have been allowable if incurred after the date of the federal award and **only** with the written approval of the federal awarding agency, through the Contracting Officer.

Pre-award costs cannot be incurred prior to the Selection Official signing the Selection Statement and Analysis.

Pre-award expenditures are made at the selectee's risk. EERE is not obligated to reimburse costs: (1) in the absence of appropriations; (2) if an award is not made; or (3) if an award is made for a lesser amount than the selectee anticipated.

**1. National Environmental Policy Act (NEPA) Requirements Related to Pre-Award Costs**

EERE's decision whether and how to distribute federal funds under this FOA is subject to NEPA. Applicants should carefully consider and should seek legal counsel or other expert advice before taking any action related to the proposed project that would have an adverse effect on the environment or limit the choice of reasonable alternatives prior to EERE completing the NEPA review process.

EERE does not guarantee or assume any obligation to reimburse pre-award costs incurred prior to receiving written authorization from the Contracting Officer. If the applicant elects to undertake activities that DOE determines may have an adverse effect on the environment or limit the choice of reasonable alternatives prior to receiving such written authorization from the Contracting Officer, the applicant is doing so at risk of not receiving federal funding for its project and such costs may not be recognized as allowable cost share. Nothing contained in the pre-award cost reimbursement regulations or any pre-award costs approval letter from the Contracting Officer overrides the requirement to obtain the written authorization from the Contracting Officer prior to taking any action that may have an adverse effect on the environment or limit the choice of reasonable alternatives. Likewise, if an application is selected for negotiation of award, and the prime

*Questions about this FOA? Email [WETOFOA@ee.doe.gov](mailto:WETOFOA@ee.doe.gov)*

*Problems with EERE eXCHANGE? Email [EERE-eXCHANGESupport@hq.doe.gov](mailto:EERE-eXCHANGESupport@hq.doe.gov) Include FOA name and number in subject line.*

---

---

recipient elects to undertake activities that are not authorized for federal funding by the Contracting Officer in advance of EERE completing a NEPA review, the prime recipient is doing so at risk of not receiving federal funding and such costs may not be recognized as allowable cost share.

### **iii. Performance of Work in the United States (Foreign Work Waiver)**

#### **1. Requirement**

All work performed under awards issued under this FOA must be performed in the United States. The prime recipient must flow down this requirement to its subrecipients.

#### **2. Failure to Comply**

If the prime recipient fails to comply with the Performance of Work in the United States requirement, EERE may deny reimbursement for the work conducted outside the United States and such costs may not be recognized as allowable recipient cost share. The prime recipient is responsible should any work under this award be performed outside the United States, absent a waiver, regardless of whether the work is performed by the prime recipient, subrecipients, contractors or other project partners.

#### **3. Waiver**

To seek a foreign work waiver, the applicant must submit a written waiver request to EERE. [Appendix B lists the information that must be included in a request for a foreign work waiver.](#)

Save the waiver request(s) in a single PDF file. The applicant does not have the right to appeal EERE's decision concerning a waiver request.

### **iv. Construction**

Recipients are required to obtain written authorization from the Contracting Officer before incurring any major construction costs.

### **v. Foreign Travel**

Foreign travel costs are not allowable under this FOA.

### **vi. Equipment and Supplies**

Property disposition may be required at the end of a project if the current fair market value of property exceeds \$5,000. For-profit entity disposition requirements are set forth at 2 CFR 910.360. Property disposition requirements for other non-federal entities are set forth in 2 CFR 200.310 – 200.316.

---

**vii. Build America Buy America Requirements for Infrastructure Projects**

Pursuant to the Build America Buy America Act, subtitle IX of BIL (Buy America, or BABA), federally assisted projects that involve infrastructure work, undertaken by applicable recipient types, require that:

- All iron, steel, and manufactured products used in the infrastructure work are produced in the United States; and
- All construction materials used in the infrastructure work are manufactured in the United States.

Whether a given project must apply this requirement is project-specific and dependent on several factors, such as the recipient's entity type, whether the work involves "infrastructure," as defined in Section 70914 of the BIL, and whether the infrastructure in question is publicly owned or serves a public function.

Applicants are strongly encouraged to consult Appendix C of this FOA to determine whether their project may have to apply this requirement, both to make an early determination as to the need of a waiver, as well as to determine what impact, if any, this requirement may have on the proposed project's budget.

Please note that, based on implementation guidance from the Office of Management and Budget issued on April 18, 2022, the Buy America requirements of the BIL do not apply to DOE projects in which the prime recipient is a for-profit entity; the requirements only apply to projects whose prime recipient is a "non-Federal entity," e.g., a State, local government, Indian tribe, Institution of Higher Education, or nonprofit organization. Subawards should conform to the terms of the prime award from which they flow; in other words, for-profit prime recipients are not required to flow down these Buy America requirements to subrecipients, even if those subrecipients are non-Federal entities as defined above. Conversely, prime recipients which are non-Federal entities must flow the Buy America requirements down to all subrecipients, even if those subrecipients are for-profit entities. Finally, for all applicants—both non-Federal entities and for-profit entities—DOE is including a Program Policy Factor that the Selection Official may consider in determining which Full Applications to select for award negotiations that considers whether the applicant has made a commitment to procure U.S. iron, steel, manufactured products, and construction materials in its project.

*Questions about this FOA? Email [WETOFOA@ee.doe.gov](mailto:WETOFOA@ee.doe.gov)*

*Problems with EERE eXCHANGE? Email [EERE-eXCHANGESupport@hq.doe.gov](mailto:EERE-eXCHANGESupport@hq.doe.gov) Include FOA name and number in subject line.*

---

---

The DOE financial assistance agreement will require each recipient to: (1) fulfill the commitments made in its application regarding the procurement of U.S.-produced products and (2) fulfill the commitments made in its application regarding the procurement of other key component metals and domestically manufactured products that are deemed available in sufficient and reasonably available quantities or of a satisfactory quality at the time of award negotiation. Applicants may seek waivers of these requirements in very limited circumstances and for good cause shown. Further details on requesting a waiver can be found in Appendix C and the terms and conditions of an award.

Applicants are strongly encouraged to consult Appendix C for more information.

### **viii. Lobbying**

Recipients and subrecipients may not use any federal funds to influence or attempt to influence, directly or indirectly, congressional action on any legislative or appropriation matters.

Recipients and subrecipients are required to complete and submit SF-LLL, “Disclosure of Lobbying Activities” (<https://www.grants.gov/web/grants/forms/sf-424-individual-family.html>) to ensure that non-federal funds have not been paid and will not be paid to any person for influencing or attempting to influence any of the following in connection with the application:

- An officer or employee of any federal agency;
- A Member of Congress;
- An officer or employee of Congress; or
- An employee of a Member of Congress.

### **ix. Risk Assessment**

Pursuant to 2 CFR 200.206, DOE will conduct an additional review of the risk posed by applications submitted under this FOA. Such risk assessment will consider:

1. Financial stability;
2. Quality of management systems and ability to meet the management standards prescribed in 2 CFR 200 as amended and adopted by 2 CFR 910;
3. History of performance;
4. Audit reports and findings; and
5. The applicant's ability to effectively implement statutory, regulatory, or other requirements imposed on non-federal entities.

DOE may make use of other publicly available information and the history of an applicant's performance under DOE or other federal agency awards.

Depending on the severity of the findings and whether the findings were resolved, DOE may elect not to fund the applicant.

In addition to this review, DOE must comply with the guidelines on government-wide suspension and debarment in 2 CFR 180, and must require non-federal entities to comply with these provisions. These provisions restrict federal awards, subawards and contracts with certain parties that are debarred, suspended or otherwise excluded from or ineligible for participation in federal programs or activities.

Further, as DOE invests in critical infrastructure and funds critical and emerging technology areas, DOE also considers possible threats to United States research, technology, and economic security from undue foreign government influence when evaluating risk. If high risks are identified and cannot be sufficiently mitigated, DOE may elect to not fund the applicant.

#### **x. Invoice Review and Approval**

DOE employs a risk-based approach to determine the level of supporting documentation required for approving invoice payments. Recipients may be required to provide some or all of the following items with their requests for reimbursement:

- Summary of costs by cost categories;
- Timesheets or personnel hours report;
- Invoices/receipts for all travel, equipment, supplies, contractual, and other costs;
- UCC filing proof for equipment acquired with project funds by for-profit recipients and subrecipients;
- Explanation of cost share for invoicing period;
- Analogous information for some subrecipients; and
- Other items as required by DOE.

---

**xi. Prohibition Related to Foreign Government-Sponsored Talent Recruitment Programs****a. Prohibition**

Persons participating in a *Foreign Government-Sponsored Talent Recruitment Program of a Foreign Country of Risk* are prohibited from participating in projects selected for federal funding under this FOA. Should an award result from this FOA, the recipient must exercise ongoing due diligence to reasonably ensure that no individuals participating on the DOE-funded project are participating in a *Foreign Government-Sponsored Talent Recruitment Program of a Foreign Country of Risk*. Consequences for violations of this prohibition will be determined according to applicable law, regulations, and policy. Further, the recipient must notify DOE within five (5) business days upon learning that an individual on the project team is or is believed to be participating in a foreign government talent recruitment program of a foreign country of risk. DOE may modify and add requirements related to this prohibition to the extent required by law.

**b. Definitions**

- 1. Foreign Government-Sponsored Talent Recruitment Program.** An effort directly or indirectly organized, managed, or funded by a foreign government, or a foreign government instrumentality or entity, to recruit science and technology professionals or students (regardless of citizenship or national origin, or whether having a full-time or part-time position). Some foreign government-sponsored talent recruitment programs operate with the intent to import or otherwise acquire from abroad, sometimes through illicit means, proprietary technology or software, unpublished data and methods, and intellectual property to further the military modernization goals and/or economic goals of a foreign government. Many, but not all, programs aim to incentivize the targeted individual to relocate physically to the foreign state for the above purpose. Some programs allow for or encourage continued employment at United States research facilities or receipt of federal research funds while concurrently working at and/or receiving compensation from a foreign institution, and some direct participants not to disclose their participation to U.S. entities. Compensation could take many forms including cash, research funding, complimentary foreign travel, honorific titles, career advancement opportunities, promised future compensation, or other types of remuneration or consideration, including in-kind compensation.



- 
2. **Foreign Country of Risk.** DOE has designated the following countries as foreign countries of risk: Iran, North Korea, Russia, and China. This list is subject to change.

**xii. Affirmative Action and Pay Transparency Requirements**

All applicants must comply with all applicable federal labor and employment laws, including but not limited to Title VII of the Civil Rights Act of 1964, the Fair Labor Standards Act, the Occupational Safety and Health Act, and the National Labor Relations Act, which protects employees' right to bargain collectively and engage in concerted activities for the purpose of workers' mutual aid or protection.

All federally assisted construction contracts exceeding \$10,000 annually will be subject to the requirements of Executive Order 11246:

(1) Recipients, subrecipients, contractors, and subcontractors are prohibited from discriminating in employment decisions on the basis of race, color, religion, sex, sexual orientation, gender identity, or national origin.

(2) Recipients and contractors are required to take affirmative action to ensure that equal opportunity is provided in all aspects of their employment. This includes flowing down the appropriate language to all subrecipients, contractors, and subcontractors.

(3) Recipients, subrecipients, contractors, and subcontractors are prohibited from taking adverse employment actions against applicants and employees for asking about, discussing, or sharing information about their pay or, under certain circumstances, the pay of their co-workers.

DOL's Office of Federal Contractor Compliance Programs (OFCCP) uses a neutral process to schedule compliance evaluations. Consult OFCCP's Technical Assistance Guide<sup>28</sup> to gain an understanding of the requirements and possible actions the recipients, subrecipients, contractors, and subcontractors must take. Additional guidance may also be found in the National Policy Assurances, produced by DOE.

**xiii. Foreign Collaboration Considerations**

- a. Consideration of new collaborations with foreign entities and governments. The recipient will be required to provide DOE with advanced written notification of

---

<sup>28</sup> See OFCCP's Technical Assistance Guide at:

[https://www.dol.gov/sites/dolgov/files/ofccp/Construction/files/ConstructionTAG.pdf?msclkid=9e397d68c4b111e\\_c9d8e6fecb6c710ec](https://www.dol.gov/sites/dolgov/files/ofccp/Construction/files/ConstructionTAG.pdf?msclkid=9e397d68c4b111e_c9d8e6fecb6c710ec) Also see the National Policy Assurances <http://www.nsf.gov/awards/managing/rtc.jsp>

Questions about this FOA? Email [WETOFOA@ee.doe.gov](mailto:WETOFOA@ee.doe.gov)

Problems with EERE eXCHANGE? Email [EERE-eXCHANGESupport@hq.doe.gov](mailto:EERE-eXCHANGESupport@hq.doe.gov) Include FOA name and number in subject line.

---

any potential collaboration with foreign entities or governments in connection with its DOE-funded award scope. The recipient will then be required to await further guidance from DOE prior to contacting the proposed foreign entity or government regarding the potential collaboration or negotiating the terms of any potential agreement.

- b. Existing collaborations with foreign entities and governments. The recipient will be required to provide DOE with a written list of all existing foreign collaborations in which has entered in connection with its DOE-funded award scope.
- c. Description of collaborations that should be reported. In general, a collaboration will involve some provision of a thing of value to, or from, the recipient. A thing of value includes but may not be limited to all resources made available to, or from, the recipient in support of and/or related to the DOE award, regardless of whether or not they have monetary value. Things of value also may include in-kind contributions (such as office/laboratory space, data, equipment, supplies, employees, students). In-kind contributions not intended for direct use on the DOE award but resulting in provision of a thing of value from or to the DOE award must also be reported. Collaborations do not include routine workshops, conferences, use of the recipient's services and facilities by foreign investigators resulting from its standard published process for evaluating requests for access, or the routine use of foreign facilities by awardee staff in accordance with the recipient's standard policies and procedures.

## V. Application Review Information

### A. Technical Review Criteria

#### i. Concept Papers

Concept Papers are evaluated based on consideration the following factors. All sub-criteria are of equal weight.

**Concept Paper Criterion: Overall FOA Responsiveness and Viability of the Project (Weight: 100%)**

This criterion involves consideration of the following factors:

- The applicant clearly describes the proposed technology, how the technology is unique and innovative, and how the technology will advance the current state of the art;

- 
- The applicant has identified risks and challenges of the technology, regulatory and financial aspects of the proposal including possible mitigation strategies, and has shown the impact that EERE funding and the proposed project would have on the relevant field and application;
  - The applicant has the qualifications, experience, capabilities and other resources necessary to complete the proposed project; and
  - The proposed work, if successfully accomplished, would clearly meet the objectives as stated in the FOA.

## ii. Full Applications

Applications will be evaluated against the technical review criteria shown below. All sub-criteria are of equal weight.

### **Criterion 1: Technical Merit, Innovation, and Impact (45%)**

This criterion involves consideration of the following factors:

#### Technical Merit and Innovation

- Extent to which the proposed technology, process, or project is innovative or replicable;
- Degree to which the current state of the technology and the proposed advancement are clearly described;
- Extent to which the application specifically and convincingly demonstrates how the applicant will move the state of the art to the proposed advancement
- Sufficiency of technical detail in the application to assess whether the proposed work is scientifically meritorious and revolutionary, including relevant data, calculations, and discussion of prior work, with analyses that support the viability of the proposed work;
- Extent to which project has buy-in from needed stakeholders to ensure success
- Degree to which key manufacturing and supply chain challenges are considered

#### Impact of Technology Advancement

- Ability of the project to advance industry adoption and reduce overall lifetime cost of the technology;
- Extent to which the project supports the topic area objectives and target specifications and metrics;
- Potential impact of the project on advancing the state-of-the-art; and
- Extent to which the project facilitates stakeholder relationships across new or existing stakeholders to gain technical buy-in and increase potential for future deployments

*Questions about this FOA? Email [WETOFOA@ee.doe.gov](mailto:WETOFOA@ee.doe.gov)  
Problems with EERE eXCHANGE? Email [EERE-eXCHANGESupport@hq.doe.gov](mailto:EERE-eXCHANGESupport@hq.doe.gov) Include FOA name and number in subject line.*

### Project Management

- Adequacy of proposed project management systems including the ability to track scope, cost, and schedule progress and changes;
- Reasonableness of budget and spend plan as detailed in the budget justification workbook for proposed project and objectives;
- Adequacy, reasonableness, and soundness of the project schedule, as well as annual Go/No-Go decisions prior to a budget period continuation application, interim milestones, and metrics to track process;
- Adequacy of the identification of risks, including labor and community opposition or disputes, and “timely” and appropriate strategies for mitigation and resolution; and
- Soundness of a plan to expeditiously address environmental, siting, and other regulatory requirements for the project, including evaluation of resilience to climate change

### **Criterion 2: Project Research and Market Transformation Plan (25%)**

This criterion involves consideration of the following factors:

#### Research Approach, Workplan and SOPO

- Degree to which the approach and critical path have been clearly described and thoughtfully considered; and
- Degree to which the task descriptions are clear, detailed, timely, and reasonable, resulting in a high likelihood that the proposed Workplan and SOPO will succeed in meeting the project goals

#### Identification of Technical Risks

- Discussion and demonstrated understanding of the key technical risk areas involved in the proposed work and the quality of the mitigation strategies to address them

#### Baseline, Metrics, and Deliverables

- Level of clarity in the definition of the baseline, metrics, and milestones; and
- Relative to a clearly defined project baseline, the strength of the quantifiable metrics, milestones, and mid-point deliverables defined in the application, such that meaningful interim progress will be made

#### Market Transformation Plan

- Identification of target market, competitors, and distribution channels for proposed technology along with known or perceived barriers to market penetration, including mitigation plan; and

- 
- Comprehensiveness of market transformation plan including but not limited to product development and/or service plan, commercialization timeline, financing, product marketing, legal/regulatory considerations including intellectual property, infrastructure requirements, and product distribution

#### Industry Adoption Plan

- Identification of the interest and extent of industry adoption of the technology/process

#### **Criterion 3: Team and Resources (15%)**

This criterion involves consideration of the following factors:

- Capability of the Principal Investigator(s) and the proposed team to address all aspects of the proposed work with a high probability of success. The qualifications, relevant expertise, and time commitment of the individuals on the team;
- Diversity of expertise and perspectives of the team and the inclusion of industry partners that will amplify impact;
- Sufficiency of the facilities to support the work;
- Degree to which the proposed consortia/team demonstrates the ability to facilitate and expedite further demonstration, development and commercial deployment of the proposed technologies;
- Level of participation by project participants as evidenced by letter(s) of commitment and how well they are integrated into the Workplan; and
- Reasonableness of the budget and spend plan for the proposed project and objectives

#### **Criterion 4: Community Benefits Plan (15%)**

This criterion involves consideration of the following factors:

#### Diversity, Equity, Inclusion and Accessibility (DEIA)

- Clear articulation of the project's goals related to diversity, equity, inclusion, and accessibility;
- Quality of the project's DEIA goals, as measured by the goals' depth, breadth, likelihood of success, inclusion of appropriate and relevant SMART milestones, and overall project integration;
- Degree of commitment and ability to track progress toward meeting each of the DEIA goals; and
- Extent of engagement of organizations that represent disadvantaged communities as a core element of their mission, including Minority Serving Institutions (MSIs), Minority Business Entities, and nonprofit or community-based organizations

*Questions about this FOA? Email [WETOFOA@ee.doe.gov](mailto:WETOFOA@ee.doe.gov)*

*Problems with EERE eXCHANGE? Email [EERE-eXCHANGESupport@hq.doe.gov](mailto:EERE-eXCHANGESupport@hq.doe.gov) Include FOA name and number in subject line.*

### Energy Equity

- Clear workplan tasks, staffing, research, and timeline for engaging energy equity stakeholders and/or evaluating the possible near and long-term implications of the project for the benefit of the American public, including, but not limited to public health and public prosperity benefits;
- Approach, methodology, and expertise articulated in the plan for addressing energy equity and justice issues associated with the technology innovation; and
- Likelihood that the plan will result in improved understanding of distributional public benefits and costs related to the innovation if successful

### Workforce Implications

- Clear and comprehensive workplan tasks, staffing, research, and timeline for engaging workforce stakeholders and/or evaluating the possible near- and long-term implications of the project for the U.S. workforce;
- Approach to document the knowledge, skills, and abilities of the workforce required for successful commercial deployment of innovations resulting from this research; and
- Likelihood that the plan will result in improved understanding of the workforce implications related to the innovation if successful

### **iii. Criteria for Replies to Reviewer Comments**

DOE has not established separate criteria to evaluate Replies to Reviewer Comments. Instead, Replies to Reviewer Comments are attached to the original applications and evaluated as an extension of the Full Application.

## **B. Standards for Application Evaluation**

Applications that are determined to be eligible will be evaluated in accordance with this FOA, by the standards set forth in EERE's Notice of Objective Merit Review Procedure (76 Fed. Reg. 17846, March 31, 2011) and the guidance provided in the "DOE Merit Review Guide for Financial Assistance," effective September 2020, which is available at: <https://energy.gov/management/downloads/merit-review-guide-financial-assistance-and-unsolicited-proposals-current>.

---

## C. Other Selection Factors

### i. Program Policy Factors

In addition to the above criteria, the Selection Official may consider the following program policy factors in determining which Full Applications to select for award negotiations:

- The degree to which the proposed project exhibits technological diversity when compared to the existing DOE project portfolio and other projects selected from the subject FOA;
- The degree to which the proposed project, including proposed cost share, optimizes the use of available EERE funding to achieve programmatic objectives;
- The level of industry involvement and demonstrated ability to accelerate demonstration and commercialization and overcome key market barriers;
- The degree to which the proposed project is likely to lead to increased high-quality employment and manufacturing in the United States;
- The degree to which the proposed project will accelerate transformational technological advances in areas that industry by itself is not likely to undertake because of technical and financial uncertainty;
- The degree to which the proposed project, or group of projects, represent a desired geographic distribution (considering past awards and current applications);
- The degree to which the proposed project incorporates applicant or team members from Minority Serving Institutions (e.g., Historically Black Colleges and Universities (HBCUs)/Other Minority Institutions (OMIs)); and partnerships with Minority Business Enterprises, minority-owned businesses, woman-owned businesses, veteran-owned businesses, or Indian tribes;
- The degree to which the proposed project, when compared to the existing DOE project portfolio and other projects to be selected from the subject FOA, contributes to the total portfolio meeting the goals reflected in the Community Benefits Plan criteria; and
- The degree to which the proposed project will employ procurement of U.S. iron, steel, manufactured products, and construction materials.
- The degree to which the proposed project contributes to the diversity of organizations and organization types and sizes selected from the subject FOA when compared to the existing DOE project portfolio.
- The degree to which the proposed project avoids duplication/overlap with other publicly or privately funded work.

## **D. Evaluation and Selection Process**

### **i. Overview**

The evaluation process consists of multiple phases; each includes an initial eligibility review and a thorough technical review. Rigorous technical reviews of eligible submissions are conducted by reviewers that are experts in the subject matter of the FOA. Ultimately, the Selection Official considers the recommendations of the reviewers, along with other considerations such as program policy factors, in determining which applications to select.

### **ii. Pre-Selection Interviews**

As part of the evaluation and selection process, EERE may invite one or more applicants to participate in pre-selection interviews. Pre-selection interviews are distinct from and more formal than pre-selection clarifications (See Section V.D.iii. of the FOA). The invited applicant(s) will meet with EERE representatives to provide clarification on the contents of the Full Applications and to provide EERE an opportunity to ask questions regarding the proposed project. The information provided by applicants to EERE through pre-selection interviews contributes to EERE's selection decisions.

EERE will arrange to meet with the invited applicants in person at EERE's offices or a mutually agreed upon location. EERE may also arrange site visits at certain applicants' facilities. In the alternative, EERE may invite certain applicants to participate in a one-on-one conference with EERE via webinar, videoconference, or conference call.

EERE will not reimburse applicants for travel and other expenses relating to the pre-selection interviews, nor will these costs be eligible for reimbursement as pre-award costs.

Participation in pre-selection interviews with EERE does not signify that applicants have been selected for award negotiations.

### **iii. Pre-Selection Clarification**

EERE may determine that pre-selection clarifications are necessary from one or more applicants. Pre-selection clarifications are distinct from and less formal than pre-selection interviews. These pre-selection clarifications will solely be for the purposes of clarifying the application. The pre-selection clarifications may occur before, during or after the merit review evaluation process. Information provided by an applicant that is not necessary to address the pre-selection clarification question will not be reviewed or considered. Typically, a pre-selection clarification will be carried out through either written responses to

*Questions about this FOA? Email [WETOFOA@ee.doe.gov](mailto:WETOFOA@ee.doe.gov)  
Problems with EERE eXCHANGE? Email [EERE-eXCHANGESupport@hq.doe.gov](mailto:EERE-eXCHANGESupport@hq.doe.gov) Include FOA name and number in  
subject line.*

---



---

EERE's written clarification questions or video or conference calls with EERE representatives.

The information provided by applicants to EERE through pre-selection clarifications is incorporated in their applications and contributes to the merit review evaluation and EERE's selection decisions. If EERE contacts an applicant for pre-selection clarification purposes, it does not signify that the applicant has been selected for negotiation of award or that the applicant is among the top ranked applications.

EERE will not reimburse applicants for expenses relating to the pre-selection clarifications, nor will these costs be eligible for reimbursement as pre-award costs.

#### **iv. Recipient Responsibility and Qualifications**

DOE, prior to making a federal award with a total amount of federal share greater than the simplified acquisition threshold, is required to review and consider any responsibility and qualification information about the applicant that is in the entity information domain in [SAM.gov](https://sam.gov) (see 41 U.S.C. § 2313).

The applicant, at its option, may review information in the entity information domain in [SAM.gov](https://sam.gov) and comment on any information about itself that a federal awarding agency previously entered and is currently in the entity information domain in [SAM.gov](https://sam.gov).

DOE will consider any written comments by the applicant, in addition to the other information in the entity information domain in [SAM.gov](https://sam.gov), in making a judgment about the applicant's integrity, business ethics, and record of performance under federal awards when completing the review of risk posed by applicants as described in 2 CFR 200.206.

#### **v. Selection**

The Selection Official may consider the technical merit, the Federal Consensus Board's recommendations, program policy factors, and the amount of funds available in arriving at selections for this FOA.

### **E. Anticipated Notice of Selection and Award Negotiation Dates**

EERE anticipates notifying applicants selected for negotiation of award and negotiating awards by the dates provided on the cover page of this FOA.

## **VI. Award Administration Information**

### **A. Award Notices**

#### **i. Ineligible Submissions**

Ineligible Concept Papers and Full Applications will not be further reviewed or considered for award. The Contracting Officer will send a notification letter by email to the technical and administrative points of contact designated by the applicant in EERE eXCHANGE. The notification letter will state the basis upon which the Concept Paper or the Full Application is ineligible and not considered for further review.

#### **ii. Concept Paper Notifications**

EERE will notify applicants of its determination to encourage or discourage the submission of a Full Application. EERE will post these notifications to EERE eXCHANGE. EERE may include general comments provided from reviewers on an applicant's Concept Paper in the encourage/discourage notifications.

Applicants may submit a Full Application even if they receive a notification discouraging them from doing so. By discouraging the submission of a Full Application, EERE intends to convey its lack of programmatic interest in the proposed project. Such assessments do not necessarily reflect judgments on the merits of the proposed project. The purpose of the Concept Paper phase is to save applicants the considerable time and expense of preparing a Full Application that is unlikely to be selected for award negotiations.

#### **iii. Full Application Notifications**

EERE will notify applicants of its determination via a notification letter by email to the technical and administrative points of contact designated by the applicant in EERE eXCHANGE. The notification letter will inform the applicant whether or not its Full Application was selected for award negotiations. Alternatively, EERE may notify one or more applicants that a final selection determination on particular Full Applications will be made at a later date, subject to the availability of funds or other factors.

#### **iv. Applicants Selected for Award Negotiations**

Successful applicants will receive written notification that they have been selected for award negotiations. Receipt of a notification letter selecting a Full Application for award negotiations does not authorize the applicant to commence performance of the project. If an application is selected for award negotiations, it is not a commitment by EERE to issue an award nor is it a

guarantee of federal government funding. Applicants do not receive an award unless and until award negotiations are complete and the Contracting Officer executes the funding agreement, accessible by the prime recipient in FedConnect.

The award negotiation process takes approximately 60 days. Applicants must designate a primary and a backup point-of-contact in EERE eXCHANGE with whom EERE will communicate to conduct award negotiations. The applicant must be responsive during award negotiations (i.e., provide requested documentation) and meet the negotiation deadlines. If the applicant fails to do so or if award negotiations are otherwise unsuccessful, EERE will cancel the award negotiations and rescind the selection. EERE reserves the right to terminate award negotiations at any time for any reason.

Please refer to Section IV.J.ii. of the FOA for guidance on pre-award costs.

**v. Alternate Selection Determinations**

In some instances, an applicant may receive a notification that its application was not selected for award and EERE designated the application to be an alternate, which means EERE may consider the Full Application for federal funding in the future. A notification letter stating the Full Application is designated as an alternate does not authorize the applicant to commence performance of the project. EERE may ultimately determine to select or not select the Full Application for award negotiations.

**vi. Unsuccessful Applicants**

EERE shall promptly notify in writing each applicant whose application has not been selected for award or whose application cannot be funded because of the unavailability of appropriated funds.

**B. Administrative and National Policy Requirements**

**i. Registration Requirements**

There are several required one-time actions applicants must take before applying to this FOA. Some of these actions may take several weeks, so it is vital applicants build in enough time to complete them. Failure to complete these actions could interfere with application or negotiation deadlines or the ability to receive an award if selected. These requirements are as follows:

**1. EERE Funding Opportunity Exchange (eXCHANGE)**

---

Register and create an account on EERE eXCHANGE at <https://eere-eXCHANGE.energy.gov>. This account will allow the user to apply to any open EERE FOAs in EERE eXCHANGE.

To access [EERE eXCHANGE](#), potential applicants must have a [Login.gov](#) account. As part of the eXCHANGE registration process, new users will be directed to create an account in Login.gov. Please note that the email address associated with Login.gov must match the email address associated with the eXCHANGE account. For more information, refer to the eXCHANGE Multi-Factor Authentication (MFA) Quick Guide in the [Manuals section](#) of eXCHANGE.

Each organization or business unit, whether acting as a team or a single entity, should use only one account as the contact point for each submission. Applicants must also designate backup points of contact. **This step is required to apply to this FOA.** The eXCHANGE registration does not have a delay; however, **the remaining registration requirements below could take several weeks to process and are necessary for a potential applicant to receive an award under this FOA.**

## 2. System for Award Management

Register in SAM (<https://www.sam.gov>). Designating an Electronic Business Point of Contact (EBiz POC) and obtaining a special password called a Marketing Partner ID Number (MPIN) are important steps in SAM registration. Please update your SAM registration annually.

## 3. FedConnect

Register in FedConnect (<https://www.fedconnect.net>). To create an organization account, your organization's SAM MPIN is required. For more information about the SAM MPIN or other registration requirements, review the FedConnect Ready, Set, Go! Guide at [https://www.fedconnect.net/FedConnect/Marketing/Documents/FedConnect\\_Ready\\_Set\\_Go.pdf](https://www.fedconnect.net/FedConnect/Marketing/Documents/FedConnect_Ready_Set_Go.pdf).

## 4. Grants.gov

Register in Grants.gov (<http://www.grants.gov>) to receive automatic updates when Amendments to this FOA are posted. Please note that Letters of Intent, Concept Papers, and Full Applications will not be accepted through Grants.gov.

## 5. Electronic Authorization of Applications and Award Documents

Submission of an application and supplemental information under this FOA through electronic systems used by the DOE, including EERE eXCHANGE and

---

FedConnect, constitutes the authorized representative's approval and electronic signature.

**ii. Award Administrative Requirements**

The administrative requirements for DOE grants and cooperative agreements are contained in 2 CFR Part 200 as amended by 2 CFR Part 910.

**iii. Foreign National Participation**

All applicants selected for an award under this FOA and project participants (including subrecipients and contractors) who anticipate involving foreign nationals in the performance of an award, may be required to provide DOE with specific information about each foreign national to satisfy requirements for foreign national participation. A "foreign national" is defined as any person who is not a United States citizen by birth or naturalization. The volume and type of information collected may depend on various factors associated with the award. DOE concurrence may be required before a foreign national can participate in the performance of any work under an award.

DOE may elect to deny a foreign national's participation in the award. Likewise, DOE may elect to deny a foreign national's access to a DOE site, information, technologies, equipment, programs, or personnel.

**iv. Subaward and Executive Reporting**

Additional administrative requirements necessary for DOE grants and cooperative agreements to comply with the Federal Funding and Transparency Act of 2006 (FFATA) are contained in 2 CFR Part 170. Prime recipients must register with the new FFATA Subaward Reporting System database and report the required data on their first tier subrecipients. Prime recipients must report the executive compensation for their own executives as part of their registration profile in SAM.

**v. National Policy Requirements**

The National Policy Assurances that are incorporated as a term and condition of award are located at: <http://www.nsf.gov/awards/managing/rtc.jsp>.

**vi. Environmental Review in Accordance with National Environmental Policy Act (NEPA)**

EERE's decision whether and how to distribute federal funds under this FOA is subject to NEPA (42 U.S.C. § 4321, *et seq.*). NEPA requires federal agencies to integrate environmental values into their decision-making processes by considering the potential environmental impacts of their proposed actions. For

---

additional background on NEPA, please see DOE's NEPA website, at <https://www.energy.gov/nepa>.

While NEPA compliance is a federal agency responsibility and the ultimate decisions remain with the federal agency, all recipients selected for an award will be required to assist in the timely and effective completion of the NEPA process in the manner most pertinent to their proposed project. If DOE determines certain records must be prepared to complete the NEPA review process (e.g., biological evaluations or environmental assessments), the recipient may be required to prepare the records and the costs to prepare the necessary records may be included as part of the project costs.

## **vii. Applicant Representations and Certifications**

### **1. Lobbying Restrictions**

By accepting funds under this award, the prime recipient agrees that none of the funds obligated on the award shall be expended, directly or indirectly, to influence Congressional action on any legislation or appropriation matters pending before Congress, other than to communicate to Members of Congress as described in 18 U.S.C. § 1913. This restriction is in addition to those prescribed elsewhere in statute and regulation.

### **2. Corporate Felony Conviction and Federal Tax Liability Representations**

In submitting an application to this FOA, the applicant represents that:

- a.** It is **not** a corporation that has been convicted of a felony criminal violation under any federal law within the preceding 24 months; and
- b.** It is **not** a corporation that has any unpaid federal tax liability that has been assessed, for which all judicial and administrative remedies have been exhausted or have lapsed, and that is not being paid in a timely manner pursuant to an agreement with the authority responsible for collecting the tax liability.

For purposes of these representations, a corporation is any for-profit or nonprofit entity that has filed articles of incorporation in any of the 50 states, the District of Columbia, or the various territories of the United States [but not foreign corporations].

### **3. Nondisclosure and Confidentiality Agreements Representations**

In submitting an application to this FOA the applicant represents that:

- 
- a. It **does not and will not** require its employees or contractors to sign internal nondisclosure or confidentiality agreements or statements prohibiting or otherwise restricting its employees or contractors from lawfully reporting waste, fraud, or abuse to a designated investigative or law enforcement representative of a federal department or agency authorized to receive such information.
- b. It **does not and will not** use any federal funds to implement or enforce any nondisclosure and/or confidentiality policy, form, or agreement it uses unless it contains the following provisions:

*“These provisions are consistent with and do not supersede, conflict with, or otherwise alter the employee obligations, rights, or liabilities created by existing statute or Executive Order relating to (1) classified information, (2) communications to Congress, (3) the reporting to an Inspector General of a violation of any law, rule, or regulation, or mismanagement, a gross waste of funds, an abuse of authority, or a substantial and specific danger to public health or safety, or (4) any other whistleblower protection. The definitions, requirements, obligations, rights, sanctions, and liabilities created by controlling Executive Orders and statutory provisions are incorporated into this agreement and are controlling.”*

- (1) The limitation above shall not contravene requirements applicable to Standard Form 312 Classified Information Nondisclosure Agreement (<https://fas.org/sgp/othergov/sf312.pdf>), Form 4414 Sensitive Compartmented Information Disclosure Agreement (<https://fas.org/sgp/othergov/intel/sf4414.pdf>), or any other form issued by a federal department or agency governing the nondisclosure of classified information.
- (2) Notwithstanding the provision listed in paragraph (a), a nondisclosure or confidentiality policy form or agreement that is to be executed by a person connected with the conduct of an intelligence or intelligence-related activity, other than an employee or officer of the U.S. government, may contain provisions appropriate to the activity for which such document is to be used. Such form or agreement shall, at a minimum, require that the person will not disclose any classified information received during such activity unless specifically authorized to do so by the U.S. government. Such nondisclosure or confidentiality forms shall also make it clear that they do not bar disclosures to Congress, or to an authorized official of an executive

---

agency or the U.S. Department of Justice, that are essential to reporting a substantial violation of law.

**viii. Statement of Federal Stewardship**

EERE will exercise normal federal stewardship in overseeing the project activities performed under EERE awards. Stewardship activities include, but are not limited to, conducting site visits; reviewing performance and financial reports; providing assistance and/or temporary intervention in unusual circumstances to correct deficiencies that develop during the project; assuring compliance with terms and conditions; and reviewing technical performance after project completion to ensure that the project objectives have been accomplished.

**ix. Statement of Substantial Involvement**

EERE has substantial involvement in work performed under awards made as a result of this FOA. EERE does not limit its involvement to the administrative requirements of the award. Instead, EERE has substantial involvement in the direction and redirection of the technical aspects of the project. Substantial involvement includes, but is not limited to, the following:

1. EERE shares responsibility with the recipient for the management, control, direction, and performance of the project.
2. EERE may intervene in the conduct or performance of work under this award for programmatic reasons. Intervention includes the interruption or modification of the conduct or performance of project activities.
3. EERE may redirect or discontinue funding the project based on the outcome of EERE's evaluation of the project at the Go/No-Go decision point(s).
4. EERE participates in major project decision-making processes.

**x. Intellectual Property Management Plan (IPMP)**

As a quarter 1 milestone if selected for award, applicants must submit an executed IPMP between the members of the consortia or team.

The award will set forth the treatment of and obligations related to intellectual property rights between EERE and the individual members. The IPMP should describe how the members will handle intellectual property rights and issues between themselves while ensuring compliance with federal intellectual property laws, regulations, and policies (see Sections VIII.K.-VIII.N. of this FOA for more details on applicable federal intellectual property laws and regulations). Guidance regarding the contents of IPMP is available from EERE upon request.



The following is a list of examples of items the IPMP may cover:

- The treatment of confidential information between members (e.g., the use of NDAs);
- The treatment of background intellectual property (e.g., any requirements for identifying it or making it available);
- The treatment of inventions made under the award (e.g., any requirements for disclosing to the other members on an application, filing patent applications, paying for patent prosecution, and cross-licensing or other licensing arrangements between the members);
- The treatment of data produced, including software, under the award (e.g., any publication process or other dissemination strategies, copyrighting strategy or arrangement between members);
- Any technology transfer and commercialization requirements or arrangements between the members;
- The treatment of any intellectual property issues that may arise due to a change in membership of the consortia or team; and
- The handling of disputes related to intellectual property between the members.

**xi. Subject Invention Utilization Reporting**

To ensure that prime recipients and subrecipients holding title to subject inventions are taking the appropriate steps to commercialize subject inventions, EERE may require that each prime recipient holding title to a subject invention submit annual reports for 10 years from the date the subject invention was disclosed to EERE on the utilization of the subject invention and efforts made by prime recipient or its licensees or assignees to stimulate such utilization. The reports must include information regarding the status of development, date of first commercial sale or use, gross royalties received by the prime recipient, and such other data and information as EERE may specify.

**xii. Intellectual Property Provisions**

The standard DOE financial assistance intellectual property provisions applicable to the various types of recipients are located at <http://energy.gov/gc/standard-intellectual-property-ip-provisions-financial-assistance-awards>.

**xiii. Reporting**

Reporting requirements are identified on the Federal Assistance Reporting Checklist, attached to the award agreement.

---

**xiv. Go/No-Go Review**

Each project selected under this FOA will be subject to a periodic project evaluation referred to as a Go/No-Go Review. A Go/No-Go Review is a risk management tool and a project management best practice to ensure that, for the current phase or period of performance, technical success is definitively achieved and potential for success in future phases or periods of performance is evaluated, prior to beginning the execution of future phases. At the Go/No-Go decision points, DOE will evaluate project performance, project schedule adherence, the extent milestone objectives are met, compliance with reporting requirements, and overall contribution to the program goals and objectives. Federal funding beyond the Go/No-Go decision point (continuation funding) is contingent upon (1) availability of federal funds appropriated by Congress for the purpose of this program; (2) the availability of future-year budget authority; (3) recipient's technical progress compared to the Milestone Summary Table stated in Attachment 1 of the award; (4) recipient's submittal of required reports; (5) recipient's compliance with the terms and conditions of the award; (6) DOE's Go/No-Go decision; (7) the recipient's submission of a continuation application;<sup>29</sup> and (8) written approval of the continuation application by the Contracting Officer.

As a result of the Go/No-Go Review, DOE may, at its discretion, authorize the following actions: (1) continue to fund the project, contingent upon the availability of funds appropriated by Congress for the purpose of this program and the availability of future-year budget authority; (2) recommend redirection of work under the project; (3) place a hold on federal funding for the project, pending further supporting data or funding; or (4) discontinue funding the project because of insufficient progress, change in strategic direction, or lack of funding.

The Go/No-Go decision is distinct from a non-compliance determination. In the event a recipient fails to comply with the requirements of an award, DOE may take appropriate action, including but not limited to, redirecting, suspending or terminating the award.

---

<sup>29</sup> A continuation application is a non-competitive application for an additional budget period within a previously approved project period. At least ninety (90) days before the end of each budget period, the recipient must submit its continuation application, which includes the following information:

- i. A progress report on the project objectives, including significant findings, conclusions, or developments, and an estimate of any unobligated balances remaining at the end of the budget period. If the remaining unobligated balance is estimated to exceed 20 percent of the funds available for the budget period, explain why the excess funds have not been obligated and how they will be used in the next budget period.
- ii. A detailed budget and supporting justification if there are changes to the negotiated budget, or a budget for the upcoming budget period was not approved at the time of award.
- iii. A description of any planned changes from the SOPO and/or Milestone Summary Table.

*Questions about this FOA? Email [WETOFOA@ee.doe.gov](mailto:WETOFOA@ee.doe.gov)*

*Problems with EERE eXCHANGE? Email [EERE-eXCHANGESupport@hq.doe.gov](mailto:EERE-eXCHANGESupport@hq.doe.gov) Include FOA name and number in subject line.*

---

**xv. Conference Spending**

The recipient shall not expend any funds on a conference not directly and programmatically related to the purpose for which the grant or cooperative agreement was awarded that would defray the cost to the U.S. government of a conference held by any Executive branch department, agency, board, commission, or office for which the cost to the U.S. government would otherwise exceed \$20,000, thereby circumventing the required notification by the head of any such Executive Branch department, agency, board, commission, or office to the Inspector General (or senior ethics official for any entity without an Inspector General), of the date, location, and number of employees attending such conference.

**xvi. Uniform Commercial Code (UCC) Financing Statements**

Per 2 CFR 910.360 (Real Property and Equipment) when a piece of equipment is purchased by a for-profit recipient or subrecipient with federal funds, and when the federal share of the financial assistance agreement is more than \$1 million, the recipient or subrecipient must:

Properly record, and consent to the Department's ability to properly record if the recipient fails to do so, UCC financing statement(s) for all equipment in excess of \$5,000 purchased with project funds. These financing statement(s) must be approved in writing by the Contracting Officer prior to the recording, and they shall provide notice that the recipient's title to all equipment (not real property) purchased with federal funds under the financial assistance agreement is conditional pursuant to the terms of this section, and that the government retains an undivided reversionary interest in the equipment. The UCC financing statement(s) must be filed before the Contracting Officer may reimburse the recipient for the federal share of the equipment unless otherwise provided for in the relevant financial assistance agreement. The recipient shall further make any amendments to the financing statements or additional recordings, including appropriate continuation statements, as necessary or as the Contracting Officer may direct.

**xvii. Real Property and Equipment**

Real property and equipment purchased with project funds (federal share and recipient cost share) are subject to the requirements at 2 CFR 200.310, 200.311, 200.313, and 200.316 (non-federal entities, except for-profit entities) and 2 CFR 910.360 (for-profit entities).

For projects selected for awards under this FOA, the recipients may (1) take disposition action on the real property and equipment; or (2) continue to use the

---

real property and equipment after the conclusion of the award period of performance with Contracting Officer approval. The recipient's written request for Continued Use must identify the property and include: a summary of how the property will be used (must align with the authorized project purposes); a proposed use period, (e.g., perpetuity, until fully depreciated, or a calendar date when the recipient expects to submit disposition instructions); acknowledgement that the recipient shall not sell or encumber the property or permit any encumbrance without prior written DOE approval; current fair market value of the property; and an estimated useful life or depreciation schedule for equipment.

When the property is no longer needed for authorized project purposes, the recipient must request disposition instructions from DOE. For-profit entity disposition requirements are set forth in 2 CFR 910.360. Property disposition requirements for other non-federal entities are set forth in 2 CFR 200.310 – 200.316.

**xviii. Implementation of Executive Order 13798, Promoting Free Speech and Religious Liberty**

States, local governments, and other public entities may not condition subawards in a manner that would discriminate against or otherwise disadvantage subrecipients based on their religious character.

**xix. Participants and Collaborating Organizations**

If selected for award negotiations, the selected applicant must submit a list of personnel who are proposed to work on the project, both at the recipient and subrecipient level and a list of proposed collaborating organizations prior to award. Recipients will have an ongoing responsibility to notify DOE of changes to the personnel and collaborating organizations, and submit updated information during the life of the award.

**xx. Current and Pending Support**

If selected for award negotiations, within 30 days of the selection notice, the selectee must submit: 1) current and pending support disclosures and resumes for any new PIs or senior/key personnel, and 2) updated disclosures if there have been any changes to the current and pending support submitted with the application. Throughout the life of the award, the recipient has an ongoing responsibility to submit: 1) current and pending support disclosure statements and resumes for any new PI and senior/key personnel, and 2) updated disclosures if there are changes to the current and pending support previously submitted to DOE. Also see Section IV.D.xvi.

**xxi. U.S. Manufacturing Commitments**

A primary objective of DOE's multi-billion-dollar research, development, and demonstration investments is to cultivate new research and development ecosystems, manufacturing capabilities, and supply chains for and by United States industry and labor. Therefore, in exchange for receiving taxpayer dollars to support an applicant's project, the applicant must agree to a U.S. Competitiveness provision requiring that any products embodying any subject invention or produced through the use of any subject invention will be manufactured substantially in the United States unless the recipient can show to the satisfaction of DOE that it is not commercially feasible. Award terms, including the specific U.S. Competitiveness Provision applicable to the various types of recipients and projects, are available at: <https://www.energy.gov/gc/standard-intellectual-property-ip-provisions-financial-assistance-awards>.

Please note that a subject invention is any invention conceived or first actually reduced to practice in performance of work under an award. An invention is any invention or discovery which is or may be patentable. The recipient includes any awardee, recipient, sub-awardee, or sub-recipient.

As noted in the U.S. Competitiveness Provision, if an entity cannot meet the requirements of the U.S. Competitiveness Provision, the entity may request a modification or waiver of the U.S. Competitiveness Provision. For example, the entity may propose modifying the language of the U.S. Competitiveness Provision in order to change the scope of the requirements or to provide more specifics on the application of the requirements for a particular technology. As another example, the entity may request that the U.S. Competitiveness Provision be waived in lieu of a net benefits statement or United States manufacturing plan. The statement or plan would contain specific and enforceable commitments that would be beneficial to the United States economy and competitiveness. Examples of such commitments could include manufacturing specific products in the United States, making a specific investment in a new or existing United States manufacturing facility, keeping certain activities based in the United States or supporting a certain number of jobs in the United States related to the technology. DOE may, in its sole discretion, determine that the proposed modification or waiver promotes commercialization and provides substantial United States economic benefits, and grant the request. If granted, DOE will modify the award terms and conditions for the requesting entity accordingly.

More information and guidance on the waiver and modification request process can be found in the DOE Financial Assistance Letter on this topic, available at <https://www.energy.gov/management/pf-2022-09-fal-2022-01-implementation->

---

[doe-determination-exceptional-circumstances-under](#). Additional information on DOE's Commitment to Domestic Manufacturing for DOE-funded R&D is available at <https://www.energy.gov/gc/us-manufacturing>.

The U.S. Competitiveness Provision is implemented by DOE pursuant to a Determination of Exceptional Circumstances (DEC) under the Bayh-Dole Act and DOE Patent Waivers. See Section VIII.J. Title to Subject Inventions of this FOA for more information on the DEC and DOE Patent Waivers.

**xxii. Interim Conflict of Interest Policy for Financial Assistance**

The DOE interim Conflict of Interest Policy for Financial Assistance (COI Policy)<sup>30</sup> is applicable to all non-Federal entities applying for, or that receive, DOE funding by means of a financial assistance award (e.g., a grant, cooperative agreement, or technology investment agreement) and, through the implementation of this policy by the entity, to each Investigator who is planning to participate in, or is participating in, the project funded wholly or in part under the DOE financial assistance award. The term "Investigator" means the PI and any other person, regardless of title or position, who is responsible for the purpose, design, conduct, or reporting of a project funded by DOE or proposed for funding by DOE. Recipients must flow down the requirements of the interim COI Policy to any subrecipient non-federal entities. Further, for DOE funded projects, the recipient must include all financial conflicts of interest (FCOI) (i.e., managed and unmanaged/ unmanageable) in its initial and ongoing FCOI reports.

It is understood that non-federal entities and individuals receiving DOE financial assistance awards will need sufficient time to come into full compliance with DOE's interim COI Policy. To provide some flexibility, DOE allows for a staggered implementation. Specifically, prior to award, applicants selected for award negotiations must: ensure all Investigators complete their significant financial disclosures; review the disclosures; determine whether a FCOI exists; develop and implement a management plan for FCOIs; and provide DOE with an initial FCOI report that includes all FCOIs (i.e., managed and unmanaged/ unmanageable). Recipients will have 180 days from the date of the award to come into full compliance with the other requirements set forth in DOE's interim COI Policy. Prior to award, the applicant must certify that it is, or will be within 180 days of the award, compliant with all requirements in the COI Policy.

**xxiii. Data Management Plan (if applicable)**

Each applicant whose Full Application is selected for award negotiations will be required to submit a Data Management Plan (DMP during the award

---

<sup>30</sup> DOE's interim COI Policy can be found at [PF 2022-17 FAL 2022-02 Department of Energy Interim Conflict of Interest Policy Requirements for Financial Assistance](#).

*Questions about this FOA? Email [WETOFOA@ee.doe.gov](mailto:WETOFOA@ee.doe.gov)*

*Problems with EERE eXCHANGE? Email [EERE-eXCHANGESupport@hq.doe.gov](mailto:EERE-eXCHANGESupport@hq.doe.gov) Include FOA name and number in subject line.*

---

negotiations phase. A DMP explains how, when appropriate, data generated in the course of the work performed under an EERE award will be shared and preserved to validate the results of the proposed work or how the results could be validated if the data is not shared or preserved. The DMP must provide a plan for making all research data displayed in publications resulting from the proposed work digitally accessible at the time of publications.

**xxiv. Fraud, Waste, and Abuse**

The mission of the DOE Office of Inspector General (OIG) is to strengthen the integrity, economy, and efficiency of the Department's programs and operations including deterring and detecting fraud, waste, abuse, and mismanagement. The OIG accomplishes this mission primarily through investigations, audits, and inspections of DOE activities to include grants, cooperative agreements, loans, and contracts.

The OIG maintains a hotline for reporting allegations of fraud, waste, abuse, or mismanagement. To report such allegations, please visit <https://www.energy.gov/ig/ig-hotline>.

Additionally, recipients of DOE awards must be cognizant of the requirements of [2 CFR 200.113 Mandatory disclosures](#), which states:

The non-Federal entity or applicant for a Federal award must disclose, in a timely manner, in writing to the Federal awarding agency or pass-through entity all violations of Federal criminal law involving fraud, bribery, or gratuity violations potentially affecting the Federal award. Non-Federal entities that have received a Federal award including the term and condition outlined in appendix XII of 2 CFR Part 200 are required to report certain civil, criminal, or administrative proceedings to SAM.gov. Failure to make required disclosures can result in any of the remedies described in [2 CFR 200.339](#). (See also [2 CFR part 180](#), [31 U.S.C. § 3321](#), and [41 U.S.C. § 2313](#).) [[85 FR 49539](#), Aug. 13, 2020]

Applicants and subrecipients (if applicable) are encouraged to allocate sufficient costs in the project budget to cover the costs associated for personnel and data infrastructure needs to support performance management and program evaluation needs, including but not limited to independent program and project audits to mitigate risks for fraud, waste, and abuse.

---

**xxv. Human Subjects Research**

Research involving human subjects, biospecimens, or identifiable private information conducted with DOE funding is subject to the requirements of DOE Order 443.1C, Protection of Human Research Subjects, 45 CFR Part 46, Protection of Human Subjects (subpart A which is referred to as the “Common Rule”), and 10 CFR Part 745, Protection of Human Subjects. Additional information on the DOE Human Subjects Research Program can be found at: [HUMAN SUBJECTS Human Subjects Pr... | U.S. DOE Office of Science \(SC\) \(osti.gov\)](#).

**VII. Questions/Agency Contacts**

Upon the issuance of a FOA, EERE personnel are prohibited from communicating (in writing or otherwise) with applicants regarding the FOA except through the established question and answer process described below. Questions regarding this FOA must be submitted to [WETOFOA@ee.doe.gov](mailto:WETOFOA@ee.doe.gov) no later than three (3) business days prior to the application due date and time. Please note, feedback on individual concepts will not be provided through Q&A.

All questions and answers related to this FOA will be posted on EERE eXCHANGE at: <https://eere-eXCHANGE.energy.gov>. **You must first select the FOA Number to view the questions and answers specific to this FOA.** EERE will attempt to respond to a question within three (3) business days, unless a similar question and answer has already been posted on the website.

Questions related to the registration process and use of the EERE eXCHANGE website should be submitted to [EERE-eXCHANGESupport@hq.doe.gov](mailto:EERE-eXCHANGESupport@hq.doe.gov).

**VIII. Other Information****A. FOA Modifications**

Amendments to this FOA will be posted on EERE eXCHANGE and the Grants.gov system. However, you will only receive an email when an amendment or a FOA is posted on these sites if you register for email notifications for this FOA in Grants.gov. EERE recommends that you register as soon after the release of the FOA as possible to ensure you receive timely notice of any amendments or other FOAs.

**B. Government Right to Reject or Negotiate**

EERE reserves the right, without qualification, to reject any or all applications received in response to this FOA and to select any application, in whole or in part, as a basis for negotiation and/or award.



---

## C. Commitment of Public Funds

The Contracting Officer is the only individual who can make awards or commit the government to the expenditure of public funds. A commitment by anyone other than the Contracting Officer, either express or implied, is invalid.

## D. Treatment of Application Information

Applicants should not include trade secrets or business-sensitive, proprietary, or otherwise confidential information in their application unless such information is necessary to convey an understanding of the proposed project or to comply with a requirement in the FOA. Applicants are advised to not include any critically sensitive proprietary detail.

If an application includes trade secrets or business-sensitive, proprietary, or otherwise confidential information, it is furnished to the federal government in confidence with the understanding that the information shall be used or disclosed only for evaluation of the application. Such information will be withheld from public disclosure to the extent permitted by law, including the Freedom of Information Act. Without assuming any liability for inadvertent disclosure, EERE will seek to limit disclosure of such information to its employees and to outside reviewers when necessary for merit review of the application or as otherwise authorized by law. This restriction does not limit the federal government's right to use the information if it is obtained from another source.

If an applicant chooses to submit trade secrets or business-sensitive, proprietary, or otherwise confidential information, the applicant must provide **two copies** of the submission (e.g., Concept Paper, Full Application). The first copy should be marked "non-confidential," with the information believed to be confidential deleted. The second copy should be marked "confidential" and must clearly and conspicuously identify the trade secrets or business-sensitive, proprietary, or otherwise confidential information and must be marked as described below. Failure to comply with these marking requirements may result in the disclosure of the unmarked information under the Freedom of Information Act or otherwise. The federal government is not liable for the disclosure or use of unmarked information and may use or disclose such information for any purpose as authorized by law.

The cover sheet of the Full Application, and other applicant submission must be marked as follows and identify the specific pages containing trade secrets or business-sensitive, proprietary, or otherwise confidential information:

### **Notice of Restriction on Disclosure and Use of Data:**

Pages [list applicable pages] of this document may contain trade secrets or business-sensitive, proprietary, or otherwise confidential information

---

that is exempt from public disclosure. Such information shall be used or disclosed only for evaluation purposes or in accordance with a financial assistance agreement between the submitter and the government. The government may use or disclose any information that is not appropriately marked or otherwise restricted, regardless of source. [End of Notice]

In addition, (1) the header and footer of every page that contains trade secrets or business-sensitive, proprietary, or otherwise confidential information must be marked as follows: “Contains Trade Secrets or Business-Sensitive, Proprietary, or Otherwise Confidential Information Exempt from Public Disclosure,” and (2) every line or paragraph containing such information must be clearly marked with double brackets or highlighting. DOE will make its own determination about the confidential status of the information and treat it according to its determination.

## **E. Evaluation and Administration by Non-Federal Personnel**

In conducting the merit review evaluation, the Go/No-Go Reviews and Peer Reviews, the government may seek the advice of qualified non-federal personnel as reviewers. The government may also use non-federal personnel to conduct routine, nondiscretionary administrative activities, including EERE contractors. The applicant, by submitting its application, consents to the use of non-federal reviewers/administrators. Non-federal reviewers must sign conflict of interest (COI) and non-disclosure acknowledgements (NDA) prior to reviewing an application. Non-federal personnel conducting administrative activities must sign an NDA.

## **F. Notice Regarding Eligible/Ineligible Activities**

Eligible activities under this FOA include those that describe and promote the understanding of scientific and technical aspects of specific energy technologies, but not those which encourage or support political activities such as the collection and dissemination of information related to potential, planned or pending legislation.

## **G. Notice of Right to Conduct a Review of Financial Capability**

EERE reserves the right to conduct an independent third-party review of financial capability for applicants that are selected for negotiation of award (including personal credit information of principal(s) of a small business if there is insufficient information to determine financial capability of the organization).

## **H. Requirement for Full and Complete Disclosure**

Applicants are required to make a full and complete disclosure of all information requested. Any failure to make a full and complete disclosure of the requested information may result in:

- The cancellation of award negotiations;

*Questions about this FOA? Email [WETOFOA@ee.doe.gov](mailto:WETOFOA@ee.doe.gov)*

*Problems with EERE eXCHANGE? Email [EERE-eXCHANGESupport@hq.doe.gov](mailto:EERE-eXCHANGESupport@hq.doe.gov) Include FOA name and number in subject line.*

---

- 
- The modification, suspension, and/or cancellation of a funding agreement;
  - The initiation of debarment proceedings, debarment, and/or a declaration of ineligibility for receipt of federal contracts, subcontracts, and financial assistance and benefits; and
  - Civil and/or criminal penalties.

## **I. Retention of Submissions**

EERE expects to retain copies of all Full Applications and other submissions. No submissions will be returned. By applying to EERE for funding, applicants consent to EERE's retention of their submissions.

## **J. Title to Subject Inventions**

Ownership of subject inventions is governed pursuant to the authorities listed below:

- Domestic Small Businesses, Educational Institutions, and Nonprofits: Under the Bayh-Dole Act (35 U.S.C. § 200 et seq.), domestic small businesses, educational institutions, and nonprofits may elect to retain title to their subject inventions;
- All other parties: The Federal Non-Nuclear Energy Act of 1974, 42 U.S.C. § 5908, provides that the government obtains title to new inventions unless a waiver is granted (see below);
- Class Patent Waiver: DOE has issued a class waiver that applies to this FOA. Under this class waiver, domestic large businesses may elect title to their subject inventions similar to the right provided to the domestic small businesses, educational institutions, and nonprofits by law. To avail itself of the class waiver, a domestic large business must agree that any products embodying or produced through the use of a subject invention first created or reduced to practice under this program will be substantially manufactured in the United States;
- DOE may issue and publish further DEC's on the website above prior to the issuance of awards under this FOA. DOE may require additional submissions or requirements as authorized by any applicable DEC.

## **K. Government Rights in Subject Inventions**

Where prime recipients and subrecipients retain title to subject inventions, the U.S. government retains certain rights.

### **Government Use License**

The U.S. government retains a nonexclusive, nontransferable, irrevocable, paid-up license to practice or have practiced for or on behalf of the United States any subject invention throughout the world. This license extends to contractors doing work on behalf of the government.

---

## March-In Rights

The U.S. government retains march-in rights with respect to all subject inventions. Through “march-in rights,” the government may require a prime recipient or subrecipient who has elected to retain title to a subject invention (or their assignees or exclusive licensees), to grant a license for use of the invention to a third party. In addition, the government may grant licenses for use of the subject invention when a prime recipient, subrecipient, or their assignees and exclusive licensees refuse to do so.

DOE may exercise its march-in rights only if it determines that such action is necessary under any of the four following conditions:

- The owner or licensee has not taken or is not expected to take effective steps to achieve practical application of the invention within a reasonable time;
- The owner or licensee has not taken action to alleviate health or safety needs in a reasonably satisfied manner;
- The owner has not met public use requirements specified by federal statutes in a reasonably satisfied manner; or
- The United States manufacturing requirement has not been met.

Any determination that march-in rights are warranted must follow a fact-finding process in which the recipient has certain rights to present evidence and witnesses, confront witnesses and appear with counsel and appeal any adverse decision. To date, DOE has never exercised its march-in rights to any subject inventions.

## L. Rights in Technical Data

Data rights differ based on whether data is first produced under an award or instead was developed at private expense outside the award.

“Limited Rights Data”: The U.S. government will not normally require delivery of confidential or trade secret-type technical data developed solely at private expense prior to issuance of an award, except as necessary to monitor technical progress and evaluate the potential of proposed technologies to reach specific technical and cost metrics.

Government Rights in Technical Data Produced Under Awards: The U.S. government normally retains unlimited rights in technical data produced under government financial assistance awards, including the right to distribute to the public. However, pursuant to special statutory authority, certain categories of data generated under EERE awards may be protected from public disclosure for up to five years after the data is generated (“Protected Data”). For awards permitting Protected Data, the protected data must be marked as set forth in the award’s intellectual property

terms and conditions and a listing of unlimited rights data (i.e., non-protected data) must be inserted into the data clause in the award. In addition, invention disclosures may be protected from public disclosure for a reasonable time in order to allow for filing a patent application.

## **M. Copyright**

The prime recipient and subrecipients may assert copyright in copyrightable works, such as software, first produced under the award without EERE approval. When copyright is asserted, the government retains a paid-up nonexclusive, irrevocable worldwide license to reproduce, prepare derivative works, distribute copies to the public, and to perform publicly and display publicly the copyrighted work. This license extends to contractors and others doing work on behalf of the government.

## **N. Export Control**

The United States government regulates the transfer of information, commodities, technology, and software considered to be strategically important to the United States to protect national security, foreign policy, and economic interests without imposing undue regulatory burdens on legitimate international trade. There is a network of federal agencies and regulations that govern exports that are collectively referred to as “Export Controls.” All recipients and subrecipients are responsible for ensuring compliance with all applicable United States Export Control laws and regulations relating to any work performed under a resulting award.

The recipient must immediately report to DOE any export control violations related to the project funded under the DOE award, at the recipient or subrecipient level, and provide the corrective action(s) to prevent future violations.

## **O. Prohibition on Certain Telecommunications and Video Surveillance Services or Equipment**

As set forth in 2 CFR 200.216, recipients and subrecipients are prohibited from obligating or expending project funds (federal funds and recipient cost share) to procure or obtain; extend or renew a contract to procure or obtain; or enter into a contract (or extend or renew a contract) to procure or obtain equipment, services, or systems that use *covered telecommunications equipment or services* as a substantial or essential component of any system, or as critical technology as part of any system. As described in Section 889 of Public Law 115-232, *covered telecommunications equipment* is telecommunications equipment produced by Huawei Technologies Company or ZTE Corporation (or any subsidiary or affiliate of such entities).

---

See Public Law 115-232, Section 889, 2 CFR 200.216, and 2 CFR 200.471 for additional information.

## **P. Personally Identifiable Information (PII)**

All information provided by the applicant must to the greatest extent possible exclude PII. "PII" refers to information that can be used to distinguish or trace an individual's identity, such as their name, Social Security Number, or biometric records, alone or combined with other personal or identifying information linked or linkable to a specific individual, such as date and place of birth or mother's maiden name. (See OMB Memorandum M-17-12 dated January 3, 2017.)

By way of example, applicants must screen resumes to ensure that they do not contain PII such as personal addresses, personal landline/cell phone numbers, and personal emails. **Under no circumstances should Social Security Numbers (SSNs) be included in the application.** Federal agencies are prohibited from the collecting, using, and displaying unnecessary SSNs. (See the Federal Information Security Modernization Act of 2014 (Pub. L. No. 113-283, Dec 18, 2014; 44 U.S.C. § 3551).

## **Q. Annual Independent Audits**

If a for-profit entity is a prime recipient and has expended \$750,000 or more of DOE awards during the entity's fiscal year, an annual compliance audit performed by an independent auditor is required. For additional information, please refer to 2 CFR 910.501 and Subpart F.

If an educational institution, nonprofit organization, or state/local government is a prime recipient or subrecipient and has expended \$750,000 or more of federal awards during the non-federal entity's fiscal year, a Single or Program-Specific Audit is required. For additional information, please refer to 2 CFR 200.501 and Subpart F.

Applicants and subrecipients (if applicable) should propose sufficient costs in the project budget to cover the costs associated with the audit. EERE will share in the cost of the audit at its applicable cost share ratio.

---

## APPENDIX A – COST SHARE INFORMATION

### Cost Sharing or Cost Matching

The terms “cost sharing” and “cost matching” are often used synonymously. Even the DOE Financial Assistance Regulations, 2 CFR 200.306, use both terms in the titles specific to regulations applicable to cost sharing. EERE almost always uses “cost sharing,” as it conveys the concept that non-federal share is calculated as a percentage of the Total Project Cost. An exception is the State Energy Program Regulation, 10 CFR 420.12, State Matching Contribution. Here “cost matching” for the non-federal share is calculated as a percentage of the federal funds only, rather than the Total Project Cost.

### How Cost Sharing Is Calculated

As stated above, cost sharing is calculated as a percentage of the Total Project Cost. FFRDC costs must be included in Total Project Costs. The following is an example of how to calculate cost sharing amounts for a project with \$1 million in federal funds with a minimum 20% non-federal cost sharing requirement:

- Formula: Federal share (\$) divided by federal share (%) = Total Project Cost  
Example: \$1,000,000 divided by 80% = \$1,250,000
- Formula: Total Project Cost (\$) minus federal share (\$) = Non-federal share (\$)  
Example: \$1,250,000 minus \$1,000,000 = \$250,000
- Formula: Non-federal share (\$) divided by Total Project Cost (\$) = Non-federal share (%)  
Example: \$250,000 divided by \$1,250,000 = 20%

### What Qualifies for Cost Sharing

While it is not possible to explain what specifically qualifies for cost sharing in one or two sentences, in general, if a cost is allowable under the cost principles applicable to the organization incurring the cost and is eligible for reimbursement under an EERE grant or cooperative agreement, it is allowable as cost share. Conversely, if the cost is not allowable under the cost principles and not eligible for reimbursement, it is not allowable as cost share. In addition, costs may not be counted as cost share if they are paid by the federal government under another award unless authorized by federal statute to be used for cost sharing.

The rules associated with what is allowable as cost share are specific to the type of organization that is receiving funds under the grant or cooperative agreement, though they are generally the same for all types of entities. The specific rules applicable to:

- FAR Part 31 for For-Profit entities, (48 CFR Part 31); and
- 2 CFR Part 200 Subpart E - Cost Principles for all other non-federal entities.

In addition to the above regulations, other factors may come into play such as timing of donations and length of the project period. For example, the value of 10 years of donated maintenance on a project that has a project period of five years would not be fully allowable as cost share. Only the value for the five years of donated maintenance that corresponds to the project period is allowable and may be counted as cost share.

Additionally, EERE generally does not allow pre-award costs for either cost share or reimbursement when these costs precede the signing of the appropriation bill that funds the award. In the case of a competitive award, EERE generally does not allow pre-award costs prior to the signing of the Selection Statement by the EERE Selection Official.

### **General Cost Sharing Rules on a DOE Award**

- 1. Cash Cost Share** encompasses all contributions to the project made by the recipient or subrecipient(s) for costs incurred and paid for during the project. This includes when an organization pays for personnel, supplies, or equipment for their company with organizational resources. If the cost of the item or service is reimbursed, it is cash cost share. All cost share items must be necessary to the performance of the project.
- 2. In-Kind Cost Share** encompasses all contributions to the project made by the recipient or subrecipient(s) that do not involve a payment or reimbursement and represent donated items or services. In-Kind cost share items include volunteer personnel hours, donated existing equipment, and donated existing supplies. The cash value and calculations thereof for all In-Kind cost share items must be justified and explained in the Cost Share section of the project Budget Justification. All cost share items must be necessary to the performance of the project. Consult your DOE contact if you have questions before filling out the In-Kind cost share section of the Budget Justification.
- 3. Funds from other federal sources** may **not** be counted as cost share. This prohibition includes FFRDC subrecipients. Non-federal sources include any source not originally derived from federal funds. Cost sharing commitment letters from subrecipients must be provided with the original application.
- 4. Fee or profit**, including foregone fee or profit, are not allowable as project costs (including cost share) under any resulting award. The project may incur only those costs that are allowable and allocable to the project (including cost share) as determined in accordance with the applicable cost principles prescribed in FAR Part 31 for For-Profit entities and 2 CFR Part 200 Subpart E - Cost Principles for all other non-federal entities.



## DOE Financial Assistance Rules 2 CFR Part 200 as amended by 2 CFR Part 910

As stated above, the rules associated with what is allowable cost share are generally the same for all types of organizations. Following are the rules found to be common, but again, the specifics are contained in the regulations and cost principles specific to the type of entity:

**(A)** Acceptable contributions. All contributions, including cash contributions and third-party in-kind contributions, must be accepted as part of the prime recipient's cost sharing if such contributions meet all of the following criteria:

- (1)** They are verifiable from the recipient's records.
- (2)** They are not included as contributions for any other federally-assisted project or program.
- (3)** They are necessary and reasonable for the proper and efficient accomplishment of project or program objectives.
- (4)** They are allowable under the cost principles applicable to the type of entity incurring the cost as follows:
  - a.** For-profit organizations. Allowability of costs incurred by for-profit organizations and those nonprofit organizations listed in Attachment C to OMB Circular A-122 is determined in accordance with the for-profit cost principles in 48 CFR Part 31 in the FAR, except that patent prosecution costs are not allowable unless specifically authorized in the award document. (v) Commercial Organizations. FAR Subpart 31.2—Contracts with Commercial Organizations; and
  - b.** Other types of organizations. For all other non-federal entities, allowability of costs is determined in accordance with 2 CFR Part 200 Subpart E.
- (5)** They are not paid by the federal government under another award unless authorized by federal statute to be used for cost sharing or matching.
- (6)** They are provided for in the approved budget.

**(B)** Valuing and documenting contributions

- (1)** Valuing recipient's property or services of recipient's employees. Values are established in accordance with the applicable cost principles, which mean that amounts chargeable to the project are determined on the basis of costs incurred. For real property or equipment used on the project, the cost principles authorize depreciation or use charges. The full value of the item may be applied when the item

will be consumed in the performance of the award or fully depreciated by the end of the award. In cases where the full value of a donated capital asset is to be applied as cost sharing or matching, that full value must be the lesser or the following:

- a. The certified value of the remaining life of the property recorded in the recipient's accounting records at the time of donation; or
  - b. The current fair market value. If there is sufficient justification, the Contracting Officer may approve the use of the current fair market value of the donated property, even if it exceeds the certified value at the time of donation to the project. The Contracting Officer may accept the use of any reasonable basis for determining the fair market value of the property.
- (2) Valuing services of others' employees. If an employer other than the recipient furnishes the services of an employee, those services are valued at the employee's regular rate of pay, provided these services are for the same skill level for which the employee is normally paid.
- (3) Valuing volunteer services. Volunteer services furnished by professional and technical personnel, consultants, and other skilled and unskilled labor may be counted as cost sharing or matching if the service is an integral and necessary part of an approved project or program. Rates for volunteer services must be consistent with those paid for similar work in the recipient's organization. In those markets in which the required skills are not found in the recipient organization, rates must be consistent with those paid for similar work in the labor market in which the recipient competes for the kind of services involved. In either case, paid fringe benefits that are reasonable, allowable, and allocable may be included in the valuation.
- (4) Valuing property donated by third parties.
- a. Donated supplies may include such items as office supplies or laboratory supplies. Value assessed to donated supplies included in the cost sharing or matching share must be reasonable and must not exceed the fair market value of the property at the time of the donation.
  - b. Normally only depreciation or use charges for equipment and buildings may be applied. However, the fair rental charges for land and the full value of equipment or other capital assets may be allowed, when they will be consumed in the performance of the award or fully depreciated by the end of the award, provided that the Contracting Officer has approved the charges. When use charges are applied, values must be determined in accordance with the usual accounting policies of the recipient, with the following qualifications:

- i.** The value of donated space must not exceed the fair rental value of comparable space as established by an independent appraisal of comparable space and facilities in a privately-owned building in the same locality.
  - ii.** The value of loaned equipment must not exceed its fair rental value.
  
- (5)** Documentation. The following requirements pertain to the recipient's supporting records for in-kind contributions from third parties:
  - a.** Volunteer services must be documented and, to the extent feasible, supported by the same methods used by the recipient for its own employees.
  
  - b.** The basis for determining the valuation for personal services and property must be documented.

---

## APPENDIX B – WAIVER REQUESTS FOR: 1. FOREIGN ENTITY PARTICIPATION; AND 2. FOREIGN WORK

### 1. Waiver for Foreign Entity Participation

Many of the technology areas DOE funds fall in the category of critical and emerging technologies (CETs). CETs are a subset of advanced technologies that are potentially significant to United States national and economic security.<sup>31</sup> For projects selected under this FOA, all recipients and subrecipients must be organized, chartered or incorporated (or otherwise formed) under the laws of a state or territory of the United States; have majority domestic ownership and control; and have a physical location for business operations in the United States. To request a waiver of this requirement, an applicant must submit an explicit waiver request in the Full Application.

#### Waiver Criteria

Foreign entities seeking to participate in a project funded under this FOA must demonstrate to the satisfaction of DOE that:

- a. Its participation is in the best interest of the United States industry and United States economic development;
- b. The project team has appropriate measures in place to control sensitive information and protect against unauthorized transfer of scientific and technical information;
- c. Adequate protocols exist between the United States subsidiary and its foreign parent organization to comply with export control laws and any obligations to protect proprietary information from the foreign parent organization;
- d. The work is conducted within the United States and the entity acknowledges and demonstrates that it has the intent and ability to comply with the United States Competitiveness Provision (see Section VI.B.xxi.); and
- e. The foreign entity will satisfy other conditions that may be deemed necessary by DOE to protect United States government interests.

#### Content for Waiver Request

A Foreign Entity waiver request must include the following:

- a. Information about the entity: name, point of contact, and proposed type of involvement in the project;

---

<sup>31</sup> See [Critical and Emerging Technologies List Update \(whitehouse.gov\)](https://www.whitehouse.gov).

*Questions about this FOA? Email [WETOFOA@ee.doe.gov](mailto:WETOFOA@ee.doe.gov)*

*Problems with EERE eXCHANGE? Email [EERE-eXCHANGESupport@hq.doe.gov](mailto:EERE-eXCHANGESupport@hq.doe.gov) Include FOA name and number in subject line.*

- 
- b. Country of incorporation, the extent of the ownership/level control by foreign entities, whether the entity is state owned or controlled, a summary of the ownership breakdown of the foreign entity, and the percentage of ownership/control by foreign entities, foreign shareholders, foreign state or foreign individuals;
  - c. The rationale for proposing a foreign entity participate (must address criteria above);
  - d. A description of the project's anticipated contributions to the United States economy;
    - How the project will benefit the United States, including manufacturing, contributions to employment in the United States and growth in new markets and jobs in the United States;
    - How the project will promote manufacturing of products and/or services in the United States;
  - e. A description of how the foreign entity's participation is essential to the project;
  - f. A description of the likelihood of Intellectual Property (IP) being created from the work and the treatment of any such IP; and
  - g. Countries where the work will be performed (Note: if any work is proposed to be conducted outside the United States, the applicant must also complete a separate request foreign work waiver.)

DOE may also require:

- A risk assessment with respect to IP and data protection protocols that includes the export control risk based on the data protection protocols, the technology being developed, and the foreign entity and country. These submissions could be prepared by the project lead (if not the prime recipient), but the prime recipient must make a representation to DOE as to whether it believes the data protection protocols are adequate and make a representation of the risk assessment – high, medium, or low risk of data leakage to a foreign entity.
- Additional language be added to any agreement or subagreement to protect IP, mitigate risk, or other related purposes.

DOE may require additional information before considering the waiver request.

DOE's decision concerning a waiver request is not appealable.

## 2. **Waiver for Performance of Work in the United States (Foreign Work Waiver)**

As set forth in Section IV.J.iii., all work funded under this FOA must be performed in the United States. To seek a waiver of the Performance of Work in the United States requirement, the applicant must submit an explicit waiver request in the Full Application. A separate waiver request must be submitted for each entity proposing performance of work outside of the United States.

---

Overall, a waiver request must demonstrate to the satisfaction of DOE that it would further the purposes of this FOA and is otherwise in the economic interests of the United States to perform work outside of the United States. A request for a foreign work waiver must include the following:

1. The rationale for performing the work outside the United States (“foreign work”);
2. A description of the work proposed to be performed outside the United States;
3. An explanation as to how the foreign work is essential to the project;
4. A description of the anticipated benefits to be realized by the proposed foreign work and the anticipated contributions to the U.S. economy;
5. The associated benefits to be realized and the contribution to the project from the foreign work;
6. How the foreign work will benefit the United States, including manufacturing, contributions to employment in the United States and growth in new markets and jobs in the United States;
7. How the foreign work will promote manufacturing of products and/or services in the United States;
8. A description of the likelihood of IP being created from the foreign work and the treatment of any such IP;
9. The total estimated cost (DOE and recipient cost share) of the proposed foreign work;
10. The countries in which the foreign work is proposed to be performed; and
11. The name of the entity that would perform the foreign work.

DOE may require additional information before considering the waiver request.

DOE’s decision concerning a waiver request is not appealable.

---

## APPENDIX C— REQUIRED USE OF AMERICAN IRON, STEEL, MANUFACTURED PRODUCTS, AND CONSTRUCTION MATERIALS BUY AMERICA REQUIREMENTS FOR INFRASTRUCTURE PROJECTS

### A. Definitions

For purposes of the Buy America requirements, based both on the statute and OMB Guidance Document dated April 18, 2022, the following definitions apply:

**Construction materials** includes an article, material, or supply—other than an item of primarily iron or steel; a manufactured product; cement and cementitious materials; aggregates such as stone, sand, or gravel; or aggregate binding agents or additives<sup>32</sup>—that is or consists primarily of:

- Non-ferrous metals;
- Plastic and polymer-based products (including polyvinylchloride, composite building materials, and polymers used in fiber optic cables);
- Glass (including optic glass);
- Lumber; or
- Drywall.

**Infrastructure** includes, at a minimum, the structures, facilities, and equipment for, in the United States, roads, highways, and bridges; public transportation; dams, ports, harbors, and other maritime facilities; intercity passenger and freight railroads; freight and intermodal facilities; airports; water systems, including drinking water and wastewater systems; electrical transmission facilities and systems; utilities; broadband infrastructure; and buildings and real property. Infrastructure includes facilities that generate, transport, and distribute energy.

Moreover, according to the OMB guidance document:

When determining if a program has infrastructure expenditures, Federal agencies should interpret the term “infrastructure” broadly and consider the definition provided above as illustrative and not exhaustive. When determining if a particular construction project of a type not listed in the definition above constitutes “infrastructure,” agencies should consider whether the project will serve a public function, including whether the project is publicly owned and operated, privately operated on behalf of the public, or is a place of public accommodation, as opposed to a project that is privately owned and not open to the public. Projects with the former qualities have greater indicia of infrastructure, while projects with the latter quality have fewer. Projects consisting solely of the

---

<sup>32</sup> BIL, § 70917(c)(1).

purchase, construction, or improvement of a private home for personal use, for example, would not constitute an infrastructure project.

The Agency, not the applicant, will have the final say as to whether a given project includes infrastructure, as defined herein. Accordingly, in cases where the “public” nature of the infrastructure is unclear but the other relevant criteria are met, DOE strongly recommends that applicants complete their full application with the assumption that Buy America requirements will apply to the proposed project.

**Project** means the construction, alteration, maintenance, or repair of infrastructure in the United States.

### **B. Buy America Requirements for Infrastructure Projects (“Buy America” requirements)**

In accordance with Section 70914 of the BIL, none of the project funds (includes federal share and recipient cost share) may be used for a project for infrastructure unless:

(1) all iron and steel used in the project are produced in the United States--this means all manufacturing processes, from the initial melting stage through the application of coatings, occurred in the United States;

(2) all manufactured products used in the project are produced in the United States—this means the manufactured product was manufactured in the United States; and the cost of the components of the manufactured product that are mined, produced, or manufactured in the United States is greater than 55 percent of the total cost of all components of the manufactured product, unless another standard for determining the minimum amount of domestic content of the manufactured product has been established under applicable law or regulation; and

(3) all construction materials<sup>33</sup> are produced in the United States—this means that all manufacturing processes for the construction material occurred in the United States.

The Buy America requirements only apply to articles, materials, and supplies that are consumed in, incorporated into, or affixed to an infrastructure project. As such, it does not apply to tools, equipment, and supplies, such as temporary scaffolding, brought to the construction site and removed at or before the completion of the infrastructure project. Nor does the Buy America requirements apply to equipment and furnishings, such as movable chairs, desks, and portable computer equipment, that are used at or within the finished infrastructure project, but are not an integral part of the structure or permanently affixed to the infrastructure project.

---

<sup>33</sup> Excludes cement and cementitious materials, aggregates such as stone, sand, or gravel, or aggregate binding agents or additives.

*Questions about this FOA? Email [WETOFOA@ee.doe.gov](mailto:WETOFOA@ee.doe.gov)*

*Problems with EERE eXCHANGE? Email [EERE-eXCHANGESupport@hq.doe.gov](mailto:EERE-eXCHANGESupport@hq.doe.gov) Include FOA name and number in subject line.*



These requirements must flow down to all sub-awards, all contracts, subcontracts and purchase orders for work performed under the proposed project, except where the prime recipient is a for-profit entity. Based on guidance from the Office of Management and Budget (OMB), the Buy America requirements of the BIL do not apply to DOE projects in which the prime recipient is a for-profit entity; the requirements only apply to projects whose prime recipient is a State, local government, Indian tribe, Institution of Higher Education, or non-profit organization.

For additional information related to the application and implementation of these Buy America requirements, please see OMB Memorandum M-22-11, issued April 18, 2022:

<https://www.whitehouse.gov/wp-content/uploads/2022/04/M-22-11.pdf>

Note that for all applicants—both non-Federal entities and for-profit entities—DOE is including a Program Policy Factor that the Selection Official may consider in determining which Full Applications to select for award negotiations that considers whether the applicant has made a commitment to procure U.S. iron, steel, manufactured products, and construction materials in its project.

### **C. Waivers**

The DOE financial assistance agreement will require each recipient: (1) to fulfill the commitments made in its application regarding the procurement of U.S.-produced products and (2) to fulfill the commitments made in its application regarding the procurement of other key component metals and domestically manufactured products that are deemed available in sufficient and reasonably available quantities or of a satisfactory quality at the time of award negotiation.

In limited circumstances, DOE may waive the application of the Buy America requirements where DOE determines that:

- (1) Applying the Buy America requirements would be inconsistent with the public interest;
- (2) The types of iron, steel, manufactured products, or construction materials are not produced in the United States in sufficient and reasonably available quantities or of a satisfactory quality; or
- (3) The inclusion of iron, steel, manufactured products, or construction materials produced in the United States will increase the cost of the overall project by more than 25%.

If an applicant or recipient is seeking a waiver of the Buy America requirements, it may submit a waiver request after it has been notified of its selection for award negotiations. A waiver request must include:

*Questions about this FOA? Email [WETOFOA@ee.doe.gov](mailto:WETOFOA@ee.doe.gov)  
Problems with EERE eXCHANGE? Email [EERE-eXCHANGESupport@hq.doe.gov](mailto:EERE-eXCHANGESupport@hq.doe.gov) Include FOA name and number in subject line.*

---

- A detailed justification for the use of “non-domestic” iron, steel, manufactured products, or construction materials to include an explanation as to how the non-domestic item(s) is essential to the project;
- A certification that the applicant or recipient made a good faith effort to solicit bids for domestic products supported by terms included in requests for proposals, contracts, and nonproprietary communications with potential suppliers;
- Applicant/Recipient name and Unique Entity Identifier (UEI)
- Total estimated project cost, DOE and cost-share amounts;
- Project description and location (to the extent known);
- List and description of iron or steel item(s), manufactured goods, and construction material(s) the applicant or recipient seeks to waive from Domestic Content Procurement Preference requirement, including name, cost, country(ies) of origin (if known), and relevant PSC and NAICS code for each;
- Waiver justification including due diligence performed (e.g., market research, industry outreach) by the applicant or recipient; and
- Anticipated impact if no waiver is issued

DOE may require additional information before considering the waiver request.

Waiver requests are subject to public comment periods of no less than 15 days and must be reviewed by the Made in America Office. There may be instances where an award qualifies, in whole or in part, for an existing waiver described at [DOE Buy America Requirement Waiver Requests](#).

DOE’s decision concerning a waiver request is not appealable.

## APPENDIX D – LIST OF ACRONYMS

CBP	Community Benefits Plan
CETs	Critical and Emerging Technologies
COI	Conflict of Interest
CRADA	Cooperative Research and Development Agreement
DEC	Determination of Exceptional Circumstances
DEIA	Diversity, Equity, Inclusion, and Accessibility
DMP	Data Management Plan
DOE	Department of Energy
DOI	Digital Object Identifier
DOL	Department of Labor
EERE	Energy Efficiency and Renewable Energy
FAR	Federal Acquisition Regulation
FCOI	Financial Conflicts of Interest
FFATA	Federal Funding and Transparency Act of 2006
FOA	Funding Opportunity Announcement
FOIA	Freedom of Information Act
FFRDC	Federally Funded Research and Development Center
GAAP	Generally Accepted Accounting Principles
HBCUs	Historically Black Colleges and Universities
IPMP	Intellectual Property Management Plan
IRB	Institutional Review Board
M&O	Management and Operating
MFA	Multi-Factor Authentication
MPIN	Marketing Partner ID Number
MSI	Minority-Serving institution
MYPP	Multi-Year Program Plan
NDA	Non-Disclosure Acknowledgement
NEPA	National Environmental Policy Act
NNSA	National Nuclear Security Agency
NSF	National Science Foundation
OFCCP	Office of Federal Contractor Compliance Programs
OIG	Office of Inspector General
OMB	Office of Management and Budget
OSS	Open-Source Software
OSTI	Office of Scientific and Technical Information
OTA	Other Transactions Authority
PII	Personal Identifiable Information
RD&D	Research, Development, and Demonstration
RFI	Request for Information
RFP	Request for Proposal
SAM	System for Award Management

Questions about this FOA? Email [WETOFOA@ee.doe.gov](mailto:WETOFOA@ee.doe.gov)

Problems with EERE eXCHANGE? Email [EERE-eXCHANGESupport@hq.doe.gov](mailto:EERE-eXCHANGESupport@hq.doe.gov) Include FOA name and number in subject line.

SciENCv	Science Experts Network Curriculum Vita
SMART	Specific, Measurable, Attainable, Realistic, and Timely
SOPO	Statement of Project Objectives
SPOC	Single Point of Contact
STEM	Science, Technology, Engineering, and Mathematics
TAA	Technical Assistance Agreement
TIA	Technology Investment Agreement
TRL	Technology Readiness Level
UCC	Uniform Commercial Code
UEI	Unique Entity Identifier
WBS	Work Breakdown Structure
WP	Work Proposal

Questions about this FOA? Email [WETOFOA@ee.doe.gov](mailto:WETOFOA@ee.doe.gov)  
 Problems with EERE eXCHANGE? Email [EERE-eXCHANGESupport@hq.doe.gov](mailto:EERE-eXCHANGESupport@hq.doe.gov) Include FOA name and number in  
 subject line.

## APPENDIX E – COMMUNITY BENEFITS PLAN GUIDANCE

DOE is committed to pushing the frontiers of science and engineering; catalyzing high- quality domestic clean energy jobs through research, development, demonstration, and deployment; and ensuring energy equity and energy justice<sup>34</sup> for disadvantaged communities. Therefore, and in accordance with the Administration’s priority to empower workers and harness opportunities to create good union jobs as stated in EO 14008 (Executive Order on Tackling the Climate Crisis at Home and Abroad),<sup>35</sup> it is important to consider the impacts of the successful commercial deployment of any innovations resulting from this FOA on the current and future workforce.

The goal of the Community Benefits Plan is to allow the application to illustrate engagement in critical thought about implications of how the proposed work will benefit the American people and lead to broadly shared prosperity, including for workers and disadvantaged communities.<sup>36</sup> The three sections of the Community Benefits Plans are considered together because there may be significant overlap among audiences considered in workforce and disadvantaged communities.

### Example DEIA, Energy Equity, and Workforce Plan Elements

Outlined below are examples of activities that applicants might consider when developing their Community Benefits Plan. Applicants are not required to implement any of these specific examples and should propose activities that best fit their research goals, institutional environment, team composition, and other factors. Creativity is encouraged.

#### DEIA

DOE strongly encourages applicants to involve individuals and entities from disadvantaged communities. Tapping all the available talent requires intentional approaches and yields broad benefits.

Equity extends beyond diversity to equitable treatment. Equitable access to

---

<sup>34</sup> DOE defines energy justice as “the goal of achieving equity in both the social and economic participation in the energy system, while also remediating social, economic, and health burdens on those disproportionately harmed by the energy system” (Initiative for Energy Justice, 2019). Aligned with that definition, the remainder of this document refers to “energy equity” to encompass energy justice and DOE’s efforts related to Justice40. <https://www.energy.gov/diversity/articles/how-energy-justice-presidential-initiatives-and-executive-orders-shape-equity>

<sup>35</sup> <https://www.federalregister.gov/documents/2021/02/01/2021-02177/tackling-the-climate-crisis-at-home-and-abroad>

<sup>36</sup> See footnote 2 for guidance on the definition and tools to locate and identify disadvantaged communities.

*Questions about this FOA? Email [WETOFOA@ee.doe.gov](mailto:WETOFOA@ee.doe.gov)*

*Problems with EERE eXCHANGE? Email [EERE-eXCHANGESupport@hq.doe.gov](mailto:EERE-eXCHANGESupport@hq.doe.gov) Include FOA name and number in subject line.*

---

opportunity for members of the project team is paramount. This includes ensuring all members of the team, including students, are paid a living wage, provided appropriate working conditions, and provided appropriate benefits. In the execution of their project plan, applicants are asked to describe efforts in diversity, equity, inclusion, and accessibility. In this context, efforts toward DEIA are defined as:<sup>37</sup>

- 1) The practice of including the many communities, identities, races, ethnicities, backgrounds, abilities, cultures, and beliefs of the American people;
- 2) The consistent and systematic fair, just, and impartial treatment of all individuals, including protecting workers rights and adhering to Equal Employment Opportunity laws;
- 3) The recognition, appreciation, and use of the talents and skills of employees of all backgrounds; and
- 4) The provision of accommodations so that all people, including people with disabilities, can fully and independently access facilities, information and communication technology, programs, and services.

Successful plans will not only describe how the project team seeks to increase DEIA but also will describe the overall approaches to retention, engagement, professional development, and career advancement. Specifically, they will demonstrate clear approaches to ensure all team members' strengths are meaningfully leveraged, and all members are provided opportunities and paths for career development, especially including paths for interns and trainees to secure permanent positions. Diversity should be considered at all levels of the project team, not just leveraging early career individuals to meet diversity goals.

DOE strongly encourages applicants to consider partnerships to promote DEIA, justice, and workforce participation. Minority Serving Institutions, Minority Business Enterprises, minority-owned businesses, disability-owned businesses, women-owned businesses, Native American-owned businesses, veteran-owned businesses, or entities located in an underserved community that meet the eligibility requirements are encouraged to lead these partnerships as the prime applicant or participate on an application as a proposed partner to the prime applicant.

When crafting the DEIA section of the Plan, applicants should describe how

---

<sup>37</sup> <https://www.whitehouse.gov/wp-content/uploads/2021/11/Strategic-Plan-to-Advance-Diversity-Equity-Inclusion-and-Accessibility-in-the-Federal-Workforce-11.23.21.pdf>

Questions about this FOA? Email [WETOFOA@ee.doe.gov](mailto:WETOFOA@ee.doe.gov)

Problems with EERE eXCHANGE? Email [EERE-eXCHANGESupport@hq.doe.gov](mailto:EERE-eXCHANGESupport@hq.doe.gov) Include FOA name and number in subject line.

they will act to promote each of the four DEIA efforts above into their investigation. It is important to note that diversity, equity, inclusion, and accessibility are four different but related concepts that should not be conflated. For instance, you can achieve diversity without equity; all four must be addressed. Applicants could discuss how the proposed investigation could contribute to training and developing a diverse scientific workforce. Applicants could describe the efforts they plan to take, or will continue to take, to create an inclusive workplace, free from retaliation, harassment, and discrimination. Applicants could outline any barriers to creating an equitable and inclusive workplace and address the ways in which the team will work to overcome these barriers within the bounds of the specific research project. The plan could detail specific efforts to inform project team members in any capacity of their labor rights and rights under Equal Employment Opportunity laws and their free and fair chance to join a union. Note that this inclusion of informing project team members is also incorporated into awards through the National Policy Assurances.

Equal treatment of workers, including students, is necessary but overcoming institutional bias requires intentionally reducing sometimes hidden barriers to equal opportunity. Applicants could consider measures like childcare, flexible schedules, paid parental leave, pay transparency, and other supports to ensure that societal barriers do not hinder realization of DEIA intentions. Some of these considerations may result in common approaches in different sections of the plan, and that is acceptable as long as the submission is not a singular approach to all sections.

EERE especially encourages applicants to form partnerships with diverse and often underrepresented institutions, such as MSIs, labor unions, and community colleges that otherwise meet the eligibility requirements. Underrepresented institutions that meet the eligibility requirements are encouraged to lead these partnerships as the prime applicant. The DEIA section of the Plan could include engagement with underrepresented institutions to broaden the participation of disadvantaged communities and/or with local stakeholders, such as residents and businesses, entities that carry out workforce development programs, labor unions, local government, and community-based organizations that represent, support, or work with disadvantaged communities. Applicants should ensure there is transparency, accountability, and follow-through when engaging with community members and stakeholders.

Specific examples include:

- Building collaborations and partnerships with researchers and staff

*Questions about this FOA? Email [WETOFOA@ee.doe.gov](mailto:WETOFOA@ee.doe.gov)*

*Problems with EERE eXCHANGE? Email [EERE-eXCHANGESupport@hq.doe.gov](mailto:EERE-eXCHANGESupport@hq.doe.gov) Include FOA name and number in subject line.*

- at MSIs;
- Addressing barriers identified in climate surveys to remove inequities;
  - Providing anti-bias training and education in the project design and implementation teams;
  - Offering training, mentorship, education, and other support to students and early/mid-career professionals from disadvantaged communities;
  - Providing efforts toward improving a workplace culture of inclusion;
  - Developing technology and technology integration innovations to meet the needs of disadvantaged communities;
  - Creating partnerships with local communities, especially under-resourced and disadvantaged communities;
  - Voluntary recognition of a union and informing employees of their rights, regardless of their classification;
  - Making research products and engagement materials accessible in a greater variety of formats to increase accessibility of research outputs;
  - Implementing training or distributing materials to reduce stigma towards individuals with disabilities;
  - Designing technologies that strategically fit within the existing workforce for installation and maintenance of the potential innovation.

### **Energy Equity**

The Energy Equity section should articulate how project proposals will drive equitable access to, participation in, and distribution of the benefits produced from successful technology innovations to disadvantaged communities and groups. Intentional inclusion of energy equity requires evaluating the anticipated long-term costs and benefits that will accrue to disadvantaged groups as a result of the project, and how research questions and project plans are designed for and support historically disadvantaged communities' engagement in clean energy decisions. Similar to potential cost reductions or groundbreaking research findings resulting from the research, energy equity and justice benefits may be uncertain, occur over a long period of time, and have many factors within and outside the specific proposed research influencing them.

Applicants should describe the influencing factors and the most likely energy equity implications of the proposed research. Applicants should describe any



long-term constraints the proposed technology may pose to communities' access to natural resources and Tribal cultural resources. There may be existing equity research available to use and cite in this description, or the applicant could describe milestone-based efforts toward developing that understanding through this innovation. These near- and long-term outcomes may include but are not limited to: a decrease in the percent of income a household spends on energy costs (energy burden);<sup>38</sup> an increase in access to low-cost capital; a decrease in environmental exposure and burdens; increases in clean energy enterprise creation and contracting (e.g., women or minority-owned business enterprises); increased parity in clean energy technology access and adoption; increases in energy democracy, including community ownership; and an increase in energy resilience.

Specific examples include:

- Describing how a successful innovation will support economic development in diverse geographic or demographic communities;
- Creating a plan to engage equity and justice stakeholders in evaluating the broader impacts of the innovation or in the development of the research methodology;
- Describing how the proposed research strategy and methodology was informed by input from a wide variety of stakeholders;
- Creating a literature review of the equity and justice implications of the outcomes of the specific research if the innovation is successful or a plan with dedicated budget and expertise (staffing or subawardee) to evaluate the potential equity implications of successful innovation outcomes.

### **Workforce**

The Workforce section of the Community Benefits Plan should articulate the future workforce implications of the innovation or a milestone-driven plan for understanding those implications. This includes documenting the skills, knowledge, and abilities that would be required of workers installing, maintaining, and operating the technology that may be derivative of the applicant's research, as well as the training pathways and its accessibility for workers to acquire the necessary skills. There may be field-specific or relevant existing research that could be cited in this section. In addition, applicants could detail the process they will use to evaluate long-term impacts on jobs, including job growth or job loss, a change in job quality,

---

<sup>38</sup> Energy burden is defined as the percentage of gross household income spent on energy costs:  
<https://www.energy.gov/eere/slsc/low-income-community-energy-solutions>

Questions about this FOA? Email [WETOFOA@ee.doe.gov](mailto:WETOFOA@ee.doe.gov)

Problems with EERE eXCHANGE? Email [EERE-eXCHANGESupport@hq.doe.gov](mailto:EERE-eXCHANGESupport@hq.doe.gov) Include FOA name and number in subject line.

disruptions to existing industry and resulting changes to relationships between employers and employees and improvements or reductions in the ability of workers to organize for collective representation, and anything else that could result in changes to regional or national labor markets.

For additional support with developing the Workforce section of a Community Benefits Plan, please refer to the DOE's Community Benefits Plan Frequently Asked Questions (FAQs) webpage (<https://www.energy.gov/bil/community-benefits-plan-frequently-asked-questions-faqs>). This new resource, though created primarily for BIL-funded demonstration and deployment projects, may be useful for R&D projects.

Applicants will find section 2 of the FAQ ("Investing in America's Workforce") particularly helpful for understanding key federal policies, terms and concepts, as well as workforce development strategies relevant to examination of the workforce implications of applicants' proposed research.

Specific examples include:

- Outlining the challenges and opportunities for commercializing the technology in the United States;
- Creating a literature review of the workforce implications of the outcomes of the specific research if the innovation is successful, or a plan with dedicated budget and expertise (staffing or subawardee) to evaluate the potential equity implications of successful innovation outcomes;
- Creating a plan and milestones for assessing how a successful innovation will have implications for job savings or loss, either at the macroeconomic level or within specific industries;
- Describing how the project will support workforce training to address needs for successful innovation;
- Voluntary recognition of a union and informing employees of their rights, regardless of its classification;
- Creating a plan to evaluate how a successful innovation will result in potential workforce shifts between industries or geographies.

#### **Inclusion of SMART milestones**

EERE requires that the applicant's Community Benefits Plan include one Specific, Measurable, Attainable, Realistic and Timely (SMART) milestone for each budget period. An exemplary SMART milestone clearly answers the following questions:

- What needs to be accomplished?
- What measures and deliverables will be used to track progress

*Questions about this FOA? Email [WETOFOA@ee.doe.gov](mailto:WETOFOA@ee.doe.gov)*

*Problems with EERE eXCHANGE? Email [EERE-eXCHANGESupport@hq.doe.gov](mailto:EERE-eXCHANGESupport@hq.doe.gov) Include FOA name and number in subject line.*

toward accomplishment?

- What evidence suggests that the accomplishment is achievable?
- Why choose this milestone?
- When will the milestone be reached?